

Site and Soil Assessment for On-Site Effluent Management System

Assessment Site: 219 Lowes Peak Road, St Fillans NSW 2850

Client: Ivan Perich, 219 Lowes Peak Road, St Fillans NSW 2850



(Our Reference: 38356-ER01_B)

© Barnson Pty Ltd 2022. Confidential.

LIST OF CONTENTS

1.0	SYSTEM OVERVIEW	5
2.0	INTRODUCTION	6
2.1	Overview	6
2.2	Key References.....	6
2.3	Disposal System	6
3.0	SITE AND SOIL EVALUATION	9
3.1	Site Evaluators Details.....	9
3.2	Site Information	9
3.3	Desktop Assessment	10
3.4	Groundwater Review	11
3.5	Surface Water Review	11
3.1	Field Assessment Information.....	14
3.2	Soil Assessment.....	15
4.0	SITE AND SOIL LIMITATION ASSESSMENT	16
5.0	SYSTEM REQUIREMENTS.....	18
5.1	Mid-Western Regional Council Setback Requirements.....	18
	All Land Application Systems	18
	Surface Spray Irrigation	18
	Surface, Trickle & Subsurface Irrigation	18
5.2	Design Allowances – AS/NZS1547:2012 Table H1.....	18
6.0	SEPTIC TANK SELECTION AND CALCULATION.....	19
6.1	Silver Book/ NSW Health Guidelines	19
6.2	AS/NZS 1547:2012 Requirements	19
6.3	System Recommendation	20
7.0	EFFLUENT MANAGEMENT.....	21
7.1	Irrigation Area Calculation.....	21
7.2	Hydraulic Loading Method	21
7.3	Nutrient and Organic Matter Balances	21
7.4	Nitrogen Loading.....	22
7.5	Phosphorus Loading.....	23
7.6	Water Balance & Irrigation Area Size	25
8.0	EFFLUENT MANAGEMENT PRESCRIPTIONS.....	26
8.1	Effluent Treatment.....	26
8.2	Effluent Disposal- Irrigation.....	26
9.0	RECOMMENDATIONS & CONCLUSIONS	27

LIST OF TABLES

Table 1 : System Overview	5
Table 2: Details	9
Table 3: Site Particulars	9
Table 4: Desktop Assessment Details	10
Table 5: Groundwater Review	11
Table 6: Site Assessment Details.....	14
Table 7: Soil Assessment Details.....	15
Table 8: Site Limitation Assessment	16
Table 9: Soil Limitation Assessment.....	17
Table 10: System Selection Details	20

LIST OF FIGURES

Figure 1 – Site Location Plan.....	7
Figure 2 – Buffer and Setback Plan.....	8
Figure 3 – Groundwater Bore Locations.....	12
Figure 4 – Groundwater Vulnerability Map GRV_006	13

APPENDICES

Appendix A – Water Balance Calculation	
Appendix B – Borehole Logs & Laboratory Testing Results	
Appendix C – Site Setback Requirements	
Appendix D – Recommended Species List	
Appendix E – Concept Design Sketches – Irrigation System	
Appendix F – Site Photos	

Disclaimer

This report has been prepared solely for Ivan Perich in accordance with the scope provided by the client and for the purpose(s) as outlined throughout this report.

Barnson Pty Ltd accepts no liability or responsibility for or in respect of any use or reliance upon this report and its supporting material by anyone other than the client.

Project Name:	Lot 54 DP248340, 219 Lowes Peak Road, St Fillans NSW 2850
Client:	Ivan Perich
Project No.	38356
Report Reference	38356-ER01_B
Date:	6.05.2022
Revision:	Revision B

Prepared by:	Reviewed by:
	
Jeremy Wiatkowski Senior Laboratory Technician	Luke Morris B.E. MIEAust CPEng (NPER) Director

1.0 SYSTEM OVERVIEW

The following table provides a summary of the information for a sustainable onsite effluent management system proposed at Lot 54 DP248340, 219 Lowes Peak Road, St Fillans NSW 2850. The following sections of this report provide site specific details justifying the section type.

Table 1 : System Overview

Site Assessor	Jeremy Wiatkowski
Client	Ivan Perich
Site Location	"Lot 54 DP248340", 219 Lowes Peak Road, St Fillans NSW
No. of Bedrooms	Proposed 2 Bedroom Dwelling Future 3 Bedroom Dwelling Development Total 5 Bedrooms + amenities in shed
Water Source	Rainwater roof collection
Estimated Daily Flow (L/day)	840L/Day based on 7 people by at 120L/person/day
Tank Recommendation	AWTS Septic System
Tank Capacity	As per section 6.3 the minimum size tank required is >4000L
Sub Soil Assessment Class	Field assessment and subsequent laboratory tests have classed the subsoil as category 1, as shown in section 3.5.
Sub Soil Recommended Hydraulic Loading mm/day (DIR/DLR)	Drip and spray systems in category 1 soils have a design loading rate of 5mm/day. (Refer to Table 7)
Recommended Effluent Application Type	Due to the presence of category 1 soil (Gravel and Sands) and clients preference, it is recommended that irrigation fields to be utilised to disperse of onsite wastewater via an AWTS septic tank.
Effluent Design Criteria	As per section 7.0 the minimum application area was determined by calculating the requirements of hydraulic loading. As shown, 4 irrigation fields of 174.8m² each is required to dispose of the secondary treated effluent.
Notes	<ol style="list-style-type: none"> 1. It should also be noted that the AWTS requires a continuous power supply – and the system should not be switched off when not in use. 2. In the event the AWTS is powered down for more than 1-2 days, recommissioning will normally take between 2-4 weeks to establish a stable treatment process. 3. Appropriate subsurface irrigation components are to be selected. 4. AWTS's are particularly sensitive to cleaning products containing disinfectants and bleaches. They are also sensitive to herbicides, weedicides and pharmaceuticals such as antibiotics.

2.0 INTRODUCTION

2.1 Overview

Barnson Pty Ltd on behalf of Ivan Perich has prepared this report for submission to Mid-Western Regional Council. This report provides direction for sustainable on-site effluent management for a 2-bedroom residence, 3 bedroom future dwelling and proposed amenities in shed, on Lot 54 DP248340, at 219 Lowes Peak Road, St Fillans NSW (refer **Figure 1**).

2.2 Key References

The following key references were utilised as part of this assessment:

- AS/NZS 1547:2012. *On-site Domestic Wastewater Management*;
- NSW Government 1998. *On site Sewerage Management for Single Households* (The Silver Book/OSMSH);
- NSW Government 2000. *The Easy Septic Tank Guide*. Developed by Social Change Media for the NSW Department of Local Government;
- NSW Health, 2001. ‘Septic Tank and Collection Well Accreditation Guidelines’;
- Mid-Western Regional Council Local Environment Plan, 2012;
- Mid-Western Local Environment Plan, 2011;
- Murphy B.W. & Lawrie J.W. 1998. Soil Landscapes of the Dubbo 1:250 000 Sheet Report, DLWC.
- Sydney Catchment Management Authority, 2019. *Designing and Installing On-Site Wastewater Systems*;

2.3 Disposal System

Figure 1 illustrates the site location. **Figure 2** illustrates the site layout supplied by client.

The proposed effluent disposal system for this site is via an AWTS septic tank and areas to be utilised to disperse of onsite wastewater.



Figure 1 – Site Location Plan

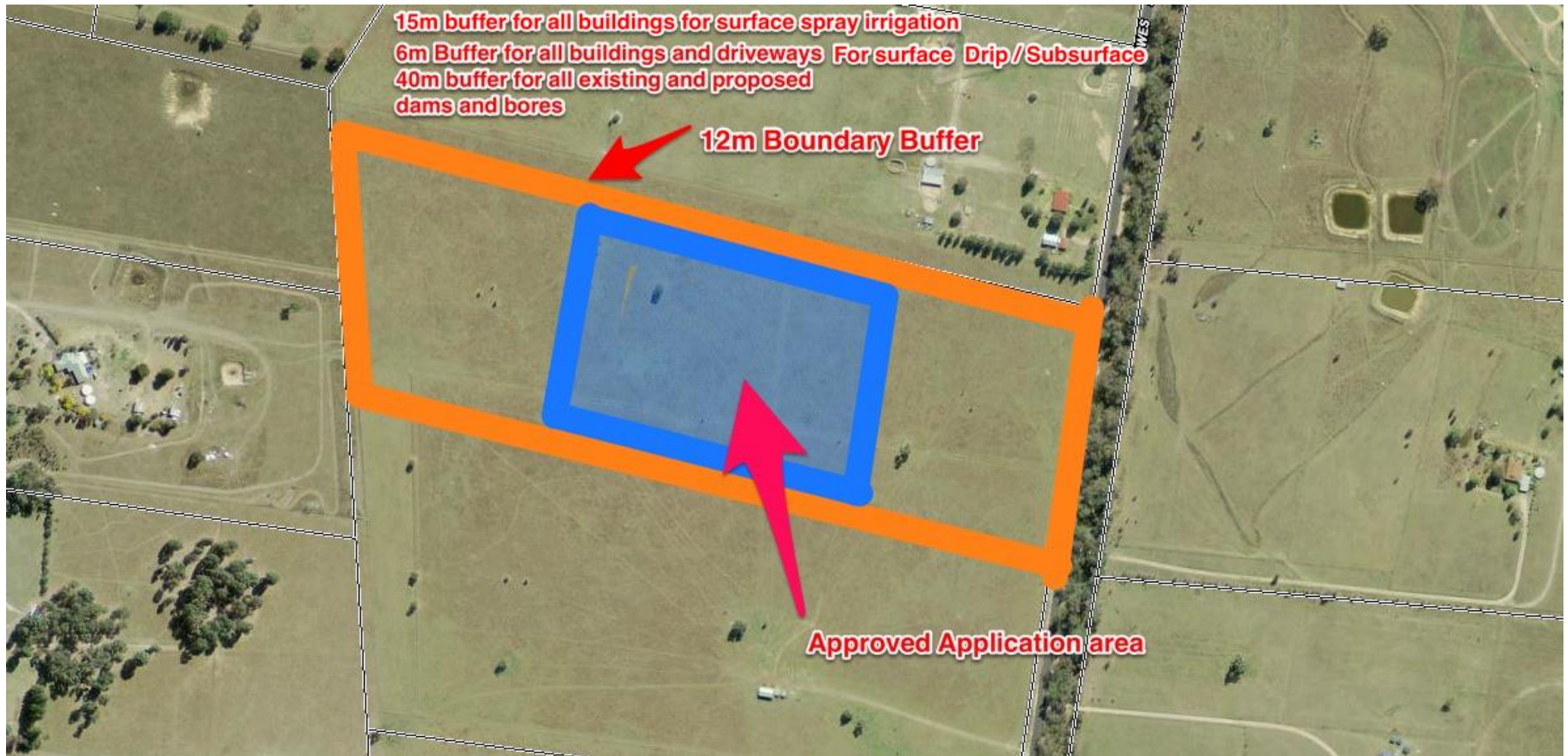

Figure 2 – Buffer and Setback Plan

3.0 SITE AND SOIL EVALUATION

3.1 Site Evaluators Details

The following table provides an overview of the evaluator's particulars.

Table 2: Details

Name / Role	Jeremy Wiatkowski
Role/ Qualifications	Senior Geotechnical Technician
Company	Barnson Pty Ltd
Company Address	1/36 Darling Street Dubbo NSW 2830
Contact Details	1300 BARNSON
Date of Assessment	9/3/2022

3.2 Site Information

The following table provides an overview of the site information.

Table 3: Site Particulars

Address/Locality	219 Lowes Peak Road, St Fillans NSW Lot 54 DP248340
Local Government Area	Mid-Western Regional Council
Owner	Ivan Perich
Developer/Builder	Owner/Builder
Intended Water Supply	Rainwater roof collection supplied
Intended Power Supply	Supplied
Local Experience	Care needs to be taken to minimise runoff and erosion. Systems commonly malfunction due to lack of ongoing maintenance. The system is to be inspected and maintained regularly in accordance with manufacturer details, Council requirements, and prescriptions identified in this report.

3.3 Desktop Assessment

The following information was obtained via desktop review of the site.

Table 4: Desktop Assessment Details

Climate Overview ¹		Annual Average Rainfall for Gulgong is 651.2mm. Warm summers with large evaporative deficit, cool winters with small evaporative deficit. The mean summer monthly rainfall (January) is 70.5mm. The mean winter rainfall (July) is 48.8mm.
Soil Landscape Reference ²	Area has been mapped within the 'Home Rule' Landscape Group. Siliceous Sands and Yellow Solodic Soils co-dominate the area.	
	Surface Conditions	Loose
	Drainage	Excessively Well Drained
	Available water holding capability	Low
	Water table depth	>150cm
	Depth to bedrock	100-300cm
	Flood hazard	Nil
	Expected Nutrient deficiencies	Nitrogen, Phosphorous
	Soil Salinity	Low
	Erosion Hazard	High
Underlying Geology ³		<i>"Colluvial polymictic gravel, sand, silt and clay; may include some eluvial in situ regolith deposits".</i>
Groundwater Review		One water bore was found within 500m of the proposed site, as illustrated in Figure 3 . The area is not mapped as being groundwater vulnerable as per the Mid-Western Regional Council LEP map GRV 006 Figure 4 .

¹ Bureau of Meteorology online Climate Data website

² NSW Soil and Land Information System

³Dubbo 1:250000

3.4 Groundwater Review

One water bore was identified as occurring within the general area of the allotment. Information relating to historic groundwater report details on water bearing zones and standing water levels is provided in the table below.

Table 5: Groundwater Review

Groundwater Bore Reference	Total Depth (m)	Water Bearing Zones (m)	Standing Water Level (m)	Yield (L/s)	Salinity Description
GW043947	29.00	25.20-25.50	14.60	0.15	Good

Using available groundwater information from local bores, it can be determined that in the local vicinity the standing water level is greater than 14m below the ground surface and the water bearing zones are greater than 25m below the ground surface.

No groundwater was encounter during the site investigation. From this information it can be determined that in this locality, subsequent contamination by primary treated effluent is not a risk factor.

3.5 Surface Water Review

The site drains to the north west to neighbouring properties.



Figure 3 – Groundwater Bore Locations

3.1 Field Assessment Information

A field inspection was conducted on 9/3/2022. The following table provides detail on the site assessment as well as the field and laboratory results.

Table 6: Site Assessment Details

Water Balance Attached	See <i>Appendix A</i>	
Exposure	Good exposure.	
Slope	The site is sloping slightly to the north west	
Run-On	None	
Seepage	None	
Erosion Potential	Low due to vegetation cover.	
Site Drainage	The site drains to a the north west to neighbouring properties	
Fill	None encountered	
Surface rock/Outcrops	None encountered	
Is there sufficient land area for:	Application system, including buffers	Yes
	Reserve application system	Yes

3.2 Soil Assessment

A soil sample was taken and returned to Barnson Pty Ltd for analysis on 9/3/2022. The sample was collected to a depth of 800mm during the site investigation as per AS1289.1.2.1.6.5.3. Laboratory and results are provided at Appendix B. Field assessment parameters were also obtained. The following table provides detail on both field and laboratory assessment results.

Table 7: Soil Assessment Details

Depth to bedrock or hardpan via field assessment		>1.5m
Depth to high soil water table via field assessment		>1.5m
Soil Analysis	pH – subsoil CaCl ₂ (lab) subsoil	5.2
	Emerson Test Result –subsoils (Lab)	5
	Liquid Limit, Plastic Limit, Plasticity Index, Linear Shrinkage. (%)	LL = 17 PL = 15 PI = 2 LS = 1.0 See Borelog in Appendix B
	Estimated Soil Category –topsoil, subsoil A,	1,1,1
	Structure massive, weak, high, moderate, strong (Field)	Structureless
	Soil Profile description	See Borelog in Appendix B
	Sub soil Permeability (from table 5.2 of AS 1547:2012)	>3(k _{sat}) (m/d) >125 (mm/hr) (Infiltration is Fast)
	Recommended Hydraulic Loading for disposal system (from Table 5.2 of AS 1547:2012)	5mm per day (For effluent disposal drip/spray)

4.0 SITE AND SOIL LIMITATION ASSESSMENT

The following two limitation tables are a standardised guide to the site and soil characteristics which may limit the suitability of the site for effluent disposal and which require attention through specific management practises. The tables have been reproduced from the NSW Government endorsed 'On-Site Sewerage Management for Single Households' (1998), Tables 8 and 9. The highlighted categories represent site and soil conditions of the land covered in this report.

Table 8: Site Limitation Assessment

Site Feature	Relevant System	Minor Limitation	Moderate Limitation	Major Limitation	Restrictive Feature
Flood Potential	All land application systems	> 1 in 20 years		Frequent below 1 in 20 years	Transport in wastewater off site
	All treatment application systems	Components above 1 in 100 years		Components below 1 in 100 years	Transport in wastewater off site system failure
Exposure	All land application systems	High sun and wind exposure		Low sun and wind exposure	Poor evaporation transpiration
Slope %	Surface Irrigation	0-6	6-12	>12	Runoff, erosion potential
	Sub-surface irrigation	0-10	10-20	>20	Runoff, erosion potential
	Absorption	0-10	10-20	>20	Runoff, erosion potential
Landform	All systems	Hillcrests, convex side slopes and plains	Concave side slopes and foot slopes	Drainage plains and incised channels	Groundwater pollution hazard, resurfacing hazard
Run-on and upslope seepage	All land Application Areas	None-low	Moderate	High, diversion not practical	Transport of wastewater off site
Erosion potential	All land application systems	No sign of erosion potential		Indications of erosion e.g. rills, mass failure	Soil degradation and off-site impact
Site drainage	All land application systems	No visible signs of surface dampness		Visible signs of surface dampness, such as moisture-tolerant veg	Groundwater pollution hazard, resurfacing hazard
Fill	All systems	No fill	Fill present		Subsidence
Land area	All systems	Area available	Area not available		Health and pollution risk
Rock and rock outcrop	All land application systems	<10%	10-20%	>20%	Limits system performance
Geology	All land application systems	None		Major geological discontinuities, fractured or highly porous regolith	Groundwater pollution hazard

Table 9: Soil Limitation Assessment

Soil feature	Relevant system	Minor limitation	Moderate limitation	Major limitation	Restrictive feature
Depth to bedrock or hardpan (m)	Surface and sub-surface irrigation	> 1.0	0.5-1.0	< 0.5	Restricts plant growth
	Absorption	> 1.5	1.0-1.5	< 1.0	Groundwater pollution hazard
Depth to seasonal water table (m)	Surface and sub-surface irrigation	> 1.0	0.5-1.0	< 0.5	Groundwater pollution hazard
	Absorption	> 1.5	1.0-1.5	< 1.0	Groundwater pollution hazard
Permeability Category	Surface and sub-surface irrigation	2b, 3 and 4	2a, 5	1 and 6	Excessive runoff and waterlogging
	Absorption	3, 4		1, 2, 5, 6	Percolation
Coarse fragments %	All systems	0-20	20-45	>40	Restricts plant growth, affects trench installation
Bulk density (g/cc) SL L, CL C	All application systems	< 1.8 < 1.6 < 1.4	> 1.8 > 1.6 >1.4		restricts plant growth, indicator of permeability
pH	All application systems	> 6.0	4.5-6.0	-	Reduces plant growth
Electrical conductivity (dS/m)	All application systems	<4	4-8	>8	Restricts plant growth
Sodicity (ESP)	Irrigation 0-40cm; absorption 0-1.2mtr	0-5	5-10	> 10	Potential for structural degradation
CEC mequiv/100g	Irrigation systems	> 15	5-15	< 5	Nutrient leaching
P sorption kg/ha	All application systems	> 6000	2000-6000	< 2000	Capacity to immobilise P
Modified Emerson Aggregate Test – depressiveness	All application systems	Classes 3-4	Class 2	class1	Potential for Structural degradation.

5.0 SYSTEM REQUIREMENTS

5.1 Mid-Western Regional Council Setback Requirements

The Mid-Western Regional Council 'On-Site Sewage Management Plan' (2008), provides recommended buffer distances. For this design, the following must be taken into consideration..

All Land Application Systems

- 80m to permanent surface waters (e.g. river, streams, lakes, etc.);
- 50m to domestic groundwater well on applicant's property and 200m to any groundwater well located on a neighbouring property;
- 40m to other waters (e.g. farm dams, intermittent waterways and drainage channels, etc.)

Surface Spray Irrigation

- 6m if area up-gradient and 3m if area down-gradient of driveways and property boundaries;
- 15m to dwellings;
- 3m to paths & walkways;
- 6m to swimming pools;

Surface Drip, Trickle & Subsurface Irrigation

- 6m if area up-gradient and 3m if area down-gradient of swimming pools, property boundaries, driveways and buildings;

Other site setback requirement as per AS/NZS 1547:2012 are provided in **Appendix C**.

An assessment of the area has indicated that the proposed treatment system adheres to the above buffer requirements.

5.2 Design Allowances - AS/NZS1547:2012 Table H1

In accordance with AS/NZS1547:2012 Table H1, the recommended design flow allowance for use in Australia, using on site rainwater roof collection supply is 120L/person/day. Given the proposed residence is 5 bedrooms in total, the number of persons is calculated at 7.

6.0 SEPTIC TANK SELECTION AND CALCULATION

6.1 Silver Book/ NSW Health Guidelines

The 'On-Site Sewerage Management for Single Households' (1998) guideline is based on the NSW Health guideline for septic tank capacity. Therefore, the calculation is the same.

Secondary effluent treated will be provided by a NSW Health accredited septic tank. The NSW Health 'Septic Tank and Collection Well Accreditation Guidelines' (2001), set a sludge allowance of 1550L irrespective of the number of persons or which the septic tank is to be designed. It should be noted that in accordance with this guideline, a septic tank designed for a minimum of 5 persons needs to be desludged approximately every 4 years.

The general formula to calculate the minimum septic tank capacity in litres is:

$$S + (DF \times N) = C$$

Sludge + (Daily Flow X No. of Persons) = Capacity of the tank

Residence - When DF = 120L/per person/per day and N =7, therefore DF x N =**840L**

$$1550L + 840L = 2390L$$

Table 2 in the NSW Health Guidelines provides a minimum of 2300L tank capacity.

6.2 AS/NZS 1547:2012 Requirements

A more conservative approach is outlined in AS/NZS1547:2012, Appendix J. A more conservative figure of 200L per person for all waste tanks is provided, giving a daily flow volume of 1400L for the residence. Therefore, a minimum capacity tank of **>4000L** is required for a residence with a design flow of 1000 - 1400L. This conservative rate is to ensure that the unit has capacity to cope with peak discharge rates or for temporary or unusual overloads and includes no allowance for food waste disposal units. This tank design capacity also allows for the storage of sludge and scum at a rate of 80L/person/year. It should be noted that the higher cost of installing a larger septic tank may be offset by a reduced pump out frequency. Too frequent pump out removes microorganisms needed for degradation of wastewater solids. The longer pump out interval has beneficial implications for conservation of resources in that the volume of seepage requiring treatment and disposal can be reduced significantly.

6.3 System Recommendation

The following table provides details on the system selection.

Table 10: System Selection Details

Consideration of connection to centralised sewerage system	Distance to sewer	>10km
	Potential for future connection?	None planned
	Potential for reticulated water?	None planned
Expected Wastewater volume (litres/day)	Residence – 2-bedroom residence, potential occupancy of 3 people, 3 - bedroom proposed future development dwelling and amenities in shed. Typical wastewater design flow is 120L/person per day in accordance with Table H3 of AS/NZS1547:2012 for households with full water reduction facilities, supplied by rainwater roof collection supply. Therefore, 7 people at 120L per person per day gives a total load of 840L/day	
Type of Treatment system best suited	4000L septic tank system– as per NSW Health accredited system https://www.health.nsw.gov.au/environment/domesticwastewater/Pages/awts.aspx	

Water conservation measures should be adapted to the greatest extent possible in the house, particularly in relation to the high water use activities of showering, clothes washing and toilet flushing. AAA rated plumbing appliances and fittings should be used. Measures including use of front loading washing machines, low volume shower roses and dual flush toilets can reduce water usage by 30-40%. Detergents low in phosphorous and sodium should be used as much as possible. Following these measures will ensure the greatest lifespan for this effluent treatment and disposal system.

7.0 EFFLUENT MANAGEMENT

Barnson Pty Ltd has analysed the proposed on site waste management system in accordance with the NSW Government endorsed 'Silver Book' (1998) and AS/NZS1547:2012 On-site Domestic Wastewater Management', with additional advice sought from the Sydney Catchment Management Authority 'Designing and installing On-site Wastewater Systems' 2019 guideline. For this site, given the climate and soil constraints, irrigation is considered the most appropriate effluent management device.

7.1 Irrigation Area Calculation

In accordance with these documents, the irrigation area for surface and subsurface irrigation must be the largest area calculated for Nitrogen and Phosphorous loading and permeability loading. Balances assume an effluent generation rate for a 6 bedroom dwelling on rainwater roof collection of 840L/day.

7.2 Hydraulic Loading Method

Hydraulic loading is the amount of liquid applied to land over a specified time interval. The hydraulic loading rate must be such that surface ponding or run-off and excessive percolation of the treated wastewater does not occur. As per the *Silver Book* 2012 the following formula can be used to estimate the size of the irrigation area for secondary treated effluent.

$$A = Q/DIR$$

Where Q = 840L/day and the DIR = 5mm/day (as per AS 1547:2012)

Therefore

$$A = 840/5$$

$$A=168 \text{ m}^2$$

7.3 Nutrient and Organic Matter Balances

In accordance with the 'Silver Book' (1998), a nutrient balance should be conducted prior to the hydraulic balance, as the calculations provide a good initial estimate of area requirements.

The Daily flow rate (Q) for this property has been assessed as is 840L/day.

7.4 Nitrogen Loading

The following formula is provided:

$$A = (C \times Q) / L_n$$

Where
A = land area (m²)
C = concentration of nutrient (mg/L)
Q = treated wastewater flow rate (L/d)
L_n = critical loading rate of nutrient (mg/m²/d)

It is appropriate to assume 20% loss by, denitrification – therefore given nitrogen has a nominal value of 37mg/L, C = 37 X 0.8 = 29.6 mg/L

In this case, L_n can be determined as 240kg/ha/yr. – this figure is obtained from Appendix 1 of the Sydney Catchment Management Authority 'Designing and installing On-site Wastewater Systems' 2019 guideline, **for Lawn - Fully Managed (Clippings Removed)** for the uptake of nitrogen.

$$L_n = 240\text{kg/ha/yr.} = 24000\text{mg/m}^2/\text{year}$$

Therefore

$$A = (29.6 \times 840 \times 365) / 24000$$
$$A = 378.1\text{m}^2$$

7.5 Phosphorus Loading

In the general formula used to determine irrigation size based on Phosphorous loading is:

$$A = P_{generated} / (P_{Absorbed} + P_{Uptake})$$

The nominal Phosphorus Sorption Capacity (mg/kg) of 200mg/kg together with the nominal bulk density value of Loams being 1.7g/cm³ (nominal value as per *Interpreting soil results*), the Phosphorus sorption capacity was estimated to be 3400kg/ha.

$P_{generated}$ = the amount of phosphorus generated over time, and is calculated as –

$P_{generate}$ = total phosphorous (TP) concentration x volume of wastewater produced over 50 years

$$\begin{aligned} &= TP \times Q \text{ L/day} \times 365 \text{ days} \times 50 \text{ years, where } 12 \text{ mg/L (as per the 'Silver} \\ &\text{book) and } Q = 840 \text{ L/day} \\ &= 12 \times 840 \times 365 \times 50 \\ &= 183960000 \text{ mg} \\ &= \underline{183.96 \text{ kg}} \end{aligned}$$

Where $P_{absorbed}$ = the amount of phosphorus that can be absorbed without leaching over 50 years. As per the 'Silver Book', this is typically 1/3 of the P sorption Value.

$$\begin{aligned} &= P_{Sorb} \times 1/3 \\ &= \underline{3400 \text{ kg/ha}} \times 1/3 \\ &= 1133.3333333 \text{ kg/ha} \\ &= \underline{0.113 \text{ kg/m}^2} \end{aligned}$$

P_{Uptake} = the amount of P uptake by vegetation over 50 years.

For Lawn - Fully Managed (Clippings Removed) 30 kg/ha/year will be used (as per SCA,2019), which is equivalent to 8.21372778mg/m²/day.

$$\begin{aligned}\text{Therefore, } P_{\text{Uptake}} &= \underline{8.21372778} \text{ (mg/m}^2\text{/day)} \times 365 \text{ (days per year)} \times 50 \text{ (years)} \\ &= 149900.53199\text{mg/m}^2\text{/day} \\ &= \underline{0.1499\text{kg/m}^2}\end{aligned}$$

$$A = P_{\text{generated}} / (P_{\text{Absorbed}} + P_{\text{Uptake}})$$

Where, $P_{\text{gen}} = \underline{183.96}$ $P_{\text{Abs}} = \underline{0.113\text{kg/m}^2}$ and $P_{\text{uptake}} = \underline{0.1499\text{kg/m}^2}$

$$A = 183.96 / (0.113 + 0.1499)$$

$$A = \underline{699\text{m}^2}$$

7.6 Water Balance & Irrigation Area Size

The purpose of the water balance is to assess the sensitivity of the design to the various inputs and outputs of the system. An irrigation area too small will result in saturated soils for long periods. An irrigation area too large will result in poor dispersal of effluent over the area and during dry periods will result in vegetation dying.

A water balance for the area is contained at **Appendix A**. This balance utilises the 70th percentile monthly rainfall data as provided in the *Bureau of Meteorology*. The water balance calculation utilised in this report is the **minimum area method** as per Table A6.2 of the *Silver Book*. Based on the average annual liquid loading, H (the amount of wastewater that maybe applied per year, is calculated as 1951.5mm/year. Therefore, using historical data, the land area required is:

$$A = 365 \times \frac{Q}{H}$$

A = land area (m²)

Q = average treated wastewater flow rate (L/day) – 840L/day

H = average annual liquid loading (mm/yr.) –1951.5mm/year

$$A = \frac{365 \times 840}{1951.5}$$

$$A = 157.11\text{m}^2$$

Therefore, based on the largest required minimum area, the Phosphorus Loading balance requirement of **699m²** is required for effluent disposal. Irrigation fields are most effective in 200m², therefore in this instance 4 fields of 174.8m² is recommended.

8.0 EFFLUENT MANAGEMENT PRESCRIPTIONS

8.1 Effluent Treatment

For this property effluent will be treated by a NSW Health Accredited system capable of achieving secondary standards suitable for surface or sub-surface irrigation. The chosen tank should be operated and maintained in accordance with the manufacture's requirements. Records of maintenance carried out on the system should be kept by the property owners for at least 10 years.

8.2 Effluent Disposal- Irrigation

Effluent can be dispersed by subsurface drip, surface drip or surface spray irrigation. Note that subsurface drip and surface drip irrigation offer advantages in utilising effluent for landscape planting, whilst sprays are effective on grassy areas. Drip and sub-surface irrigation lines require an in-line filter and a flush valve to guard against blockages. Treated effluent must be applied to vegetated areas and not bare ground.

The sizing of the effluent irrigation area is based on the nutrient balances and water balances calculated in Section 7 of this report. 4 fields of 174.8m² totalling an area of **699m²** has been assessed as being suitable for irrigation purposes. **Figure 1** illustrates an indicative area suitable for irrigation. This area is to be protected from disturbances and will not be suitable for lawn growth, play areas and foot traffic. The area should be fenced off and protected from vehicles, livestock, domestic animals and children. Lawn grass cover of the area is recommended and should be slashed, removed and kept well maintained when it is greater than 10cm long. Shrub species can also be used in the land application area. **Appendix D** provides a list of species suitable for use as illustrated in Appendix 7 of the *Silver Book*.

The effluent disposal area should be protected from potential run on and stormwater via an upslope diversion drain or beam. An example from the *Design and Installation of On Site Wastewater Treatment* (2019) guideline is provided at **Appendix E**.

It is also critical to ensure an appropriate pump to adequately service the demands of the effluent application area is met.

9.0 RECOMMENDATIONS & CONCLUSIONS

As per the 'On-Site Sewerage Management For Single Households' (1998) publication, stakeholders should be aware that all on site systems and components have a finite life and at some point will require replacement. Septic tanks and AWTs generally require replacement every 25 years, whereas effluent disposal systems can have an expected life between 5-15 years. The owner is encouraged to obtain a copy of the NSW Government "The Easy Septic Guide" (2000) available from - <https://www.olg.nsw.gov.au/wp-content/uploads/Easy-septic-guide.pdf>

The irrigation area shall be designed to accept the discharge from the AWTs and convey it securely and evenly to the land application area. The aim is to ensure uniform distribution of the effluent over the design area to help achieve effective aerobic/anaerobic decomposition within the soil. Typical design sketches as per AS 1547:2012 and *Design and Installation of On Site Wastewater Treatment* (2012) are provided at **Appendix E**.

****As stated in AS1547-2012 section 5.5.3.4, a reserve irrigation area of similar size to the current design should be considered as part of the risk management process to be available on a site for expansion or for resting of the land application system.*

Installation instructions shall be provided by the manufacturer or designer. Barnson will not be liable for the incorrect installation and/or construction of the system unless when inspected by Barnson the installation and construction of the system holds true to the design featured in this report. Installation should be in accordance with the prescriptions within AS 1547:2012.

Barnson has not verified the accuracy or completeness of this data, except otherwise stated in this report. The recommendations for the proposed system as suggested in this report are based on historical data obtained for the area. Barnson will not be liable in relation to incorrect recommendations should any information provided by the client be incorrect or have been concealed, withheld, misrepresented or otherwise not fully disclosed.

The accuracy of geotechnical engineering advice provided in this report may be limited by unobserved variations in ground conditions across the site in areas between and beyond test locations and by any restrictions in the sampling and testing which was able to be carried out, as well as by the amount of data that could be collected given the project and site constraints. These factors may lead to the possibility that actual ground conditions and materials behaviour observed at the test locations may differ from those which may be encountered elsewhere on the site.

If the sub-surface conditions are found to differ from those described in this report, we should be informed immediately to evaluate whether recommendations should be reviewed and amended if necessary.

Please do not hesitate to contact the undersigned if you have enquires regarding this report.

Yours Faithfully

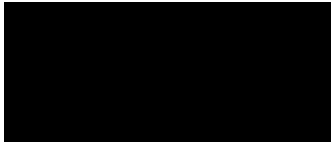

Jeremy Wiatkowski
Senior Laboratory Technician

Reviewed By

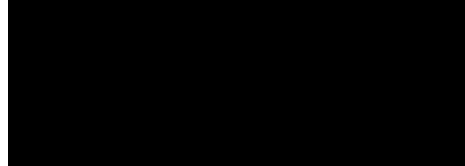

Luke Morris
B.E. MIEAust CPEng (NPER)
Director

Appendix A - Water Balance Calculation

Minimum Area Method Water Balance an Wet Weather Storage Calculations

Barnson Job No	38356-ER01_A	
Location :	St Fillans	

Design Wastewater Flow	Q	l/day	840
Design Percolation Rate	R	mm/day	5

Climate Zone	3 C	As per Soil Landscapes of Dubbo 1:250 000 Dropdown Box
--------------	-----	---

Parameter	Symbol	Formula	Units	Jan	Feb	Mar	April	May	June	July	Aug	Sept	Oct	Nov	Dec	Total
Days in Month	(D)	n/a	days	31	28	31	30	31	30	31	31	30	31	30	31	365
Precipitation (70th percentile)	(P)	n/a	mm/month	94	86	76	64	70	75	60	66	60	81	78	96	906
Evaporation	(E)	n/a	mm/month	229	178	155	104	51	46	41	58	89	130	165	229	1475
Crop Factor (as per Silver Book)	(C)	n/a	n/a	0.7	0.7	0.7	0.7	0.7	0.7	0.7	0.7	0.7	0.7	0.7	0.7	0.7

Outputs																
Evapotranspiration	(ET)	E X C	mm/month	160.3	124.6	108.5	72.8	35.7	32.2	28.7	40.6	62.3	91	115.5	160.3	1032.5
Percolation	(B)	(R/7)xD	mm/month	155.0	140.0	155.0	150.0	155.0	150.0	155.0	155.0	150.0	155.0	150.0	155.0	1825.0
Outputs		(ET +B)	mm/month	315.3	264.6	263.5	222.8	190.7	182.2	183.7	195.6	212.3	246.0	265.5	315.3	2857.5

Inputs																
Precipitation (70th percentile)	(P)	n/a	mm/month	94	86	76	64	70	75	60	66	60	81	78	96	906
Possible Effluent Irrigation	(V)	(ET + B) -P	mm/month	221.3	178.6	187.5	158.8	120.7	107.2	123.7	129.6	152.3	165.0	187.5	219.3	1951.5
Actual Effluent Production	(I)	H/12	mm/month	162.6	162.6	162.6	162.6	162.6	162.6	162.6	162.6	162.6	162.6	162.6	162.6	162.6
Inputs		(P +I)	mm/month	256.6	248.6	238.6	226.6	232.6	237.6	222.6	228.6	222.6	243.6	240.6	258.6	1068.6

Storage	(S)	(P+I) - (ET+B)	mm/month	-58.7	-16.0	-24.9	3.8	41.9	55.4	38.9	33.0	10.3	-2.4	-24.9	-56.7	
Cumulative Storage	(M)	n/a	mm	0.0	0.0	0.0	3.8	45.8	101.2	140.1	173.1	183.5	181.1	156.2	99.5	

Note - H = sum of W

Irrigation Area	(L)	365 x Q/H	m ²	157.1
Storage	(v)	Largest M	mm	183.5
		(V xL)/1000	m ³	28.8

Phosphorus Balance

Job Number 38356-ER01_A

Phosphorus Sorption capacity - calculated to a depth of 1m if possible

Weighted pSorb from lab results - as per SCA pg 203

Soil Depth	pSorption (mg/kg)	pSorption/soil layer
0-20	250	5000
20-40	420	8400
40-70	560	16800
70-100	580	17400

Weighted Psorp = Column C/thickness

Weighted Psorp = 200 mg/kg

DR USE Psorption Uptake values for soil type as per Appendix 1 of SCA pg 207

BULK Density - use the following, unless determined by lab/field (SCM pg. 207)

Soil Type	g/cm ³
Sandy Soil	1.8
Fine sandy loam*	1.7
Intermediate	1.5
clay	1.3

*Interpreting soil test results

Need to calculate the pSorption of the soil in kg/ha, using the bulk density and Weighted Psorb mg/kg

Note - use top 1m of the soil

1 hectare = 10,000m²

Therefore in the top 1m of soil = 10,000m² X 1m X Bulk density

17000 tonnes/hectare of soil (update with Bulk density)

Convert tonnes to kg 17000000 kg

Therefore the pSorption is value mg/kg X kg of soil you have

3400000000 mg/hectare

Convert mg/ha to kg/ha	3400
------------------------	------

$$\text{Irrigation Area} = \frac{P_{\text{generated}}}{P_{\text{absorbed}} + P_{\text{uptake}}}$$

P_{generated} = total phosphorus (TP) concentration x volume (V) of wastewater produced in 50 years

TP = 12mg/L (from silver book, unless otherwise obtained from effluent/AWTS outputs)

V = Q x 365 days x 50 years, where Q is daily flow L/d

Q L/day = 840

P_{generated} = 183960000 mg

Convert to kg 183.96 kg

P_{absorbed} = in soil is between 1/4 and 1/2 of the the phosphorus sorption capacity, therefore in accordance with the silver book, use 1/3

is value x 1/3 = 1133.333333 kg/ha

convert to kg/m² 0.113 kg/m²

P_{uptake} = the amount of vegetation uptake over 50 years

is value from SCA pg207 X 365 days X 50 years

Value (kg/ha/year) 30 (choose from SCM Appendix 1... or use 12 for unmaintained lawn)

Convert to mg/m²/day 8.21373 (using conversion factor from per year to per day)

Therefore total = amount mg/m²/day X 365 days X 50 years

Which is 149900.532

Convert to kg/m² 0.14990 kg/m²

$$\text{Irrigation Area} = \frac{P_{\text{generated}}}{P_{\text{absorbed}} + P_{\text{uptake}}}$$

P_{generated} = 183.96

P_{absorbed} = 0.113

P_{uptake} = 0.1499



Irrigation Area =	698.9 m ²
-------------------	----------------------

Appendix B - Borehole Logs & Laboratory Testing Results

CLIENT Ivan Perich PROJECT NAME Site Classification
PROJECT NUMBER 38356 PROJECT LOCATION 219 Lowes Peak Road, St Fillans NSW

DATE STARTED 9/3/22 COMPLETED 9/3/22 R.L. SURFACE _____ DATUM _____
DRILLING CONTRACTOR Barnson SLOPE 90° BEARING ---
EQUIPMENT Scout 1750 Drill Rig HOLE LOCATION Borehole 1
HOLE SIZE 90mm LOGGED BY HC CHECKED BY NR

NOTES

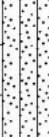
Method	Samples	Depth (m)	Graphic Log	Classification Symbol	Material Description	Dynamic Cone Penetrometer Blows / 100mm	Additional Observations
Flight Auger & Tungsten Carbide (T.C) Bit		0.0			Silty SAND: dark brown	0	TOPSOIL
		0.2		SM	Silty SAND: with gravel: brown: slightly moist: very loose to medium dense: low plasticity	3	RESIDUAL
	Disturbed Sample LS = 1.0%	1.0		SM	Silty SAND: with gravel: brown: slightly moist: dense to very dense: low plasticity	30	RESIDUAL
	Disturbed Sample LS = 6.5%	2.0		SM	Clayey Silty SAND: trace gravel: orange: slightly moist: very dense: low to medium plasticity	32	RESIDUAL
		3.0					







Borehole 1 terminated at 3m

BOREHOLE / TEST PIT WITH DCP 38356-G01A-G02A.GPJ GINT STD AUSTRALIA.GDT 12/4/22

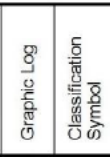
CLIENT Ivan Perich PROJECT NAME Site Classification
PROJECT NUMBER 38356 PROJECT LOCATION 219 Lowes Peak Road, St Fillans NSW

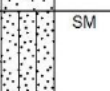
DATE STARTED 9/3/22 COMPLETED 9/3/22 R.L. SURFACE _____ DATUM _____
DRILLING CONTRACTOR Barnson SLOPE 90° BEARING ---
EQUIPMENT Scout 1750 Drill Rig HOLE LOCATION Borehole 2
HOLE SIZE 90mm LOGGED BY HC CHECKED BY NR

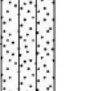
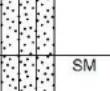
NOTES

Method	Samples	Depth (m)	Graphic Log	Classification Symbol	Material Description	Dynamic Cone Penetrometer Blows / 100mm	Additional Observations
		0			Silty SAND: dark brown	0	TOPSOIL
		0.2		SM	Silty SAND: with gravel: brown: slightly moist: very loose to medium dense: low plasticity	2	RESIDUAL
		0.5				2	
		1.0		SM	Silty SAND: with gravel: brown: slightly moist: dense to very dense: low plasticity	4	RESIDUAL
		1.5				9	
		1.6		SM	Clayey Silty SAND: trace gravel: orange: slightly moist: very dense: low to medium plasticity	15	RESIDUAL
		2.0				18	
		2.5				23	
		3.0				27	
						32	

BOREHOLE / TEST PIT WITH DCP 38356-G01A-G02A.GPJ GINT STD AUSTRALIA.GDT 12/4/22

Flight Auger & Tungsten Carbide (T.C) Bit

Borehole 2 terminated at 3m

CLIENT Ivan Perich PROJECT NAME Septic Design

PROJECT NUMBER 38356 PROJECT LOCATION 219 Lowes Peak Road, St Fillans NSW



DATE STARTED 9/3/22 COMPLETED 9/3/22 R.L. SURFACE _____ DATUM _____

DRILLING CONTRACTOR Barnson SLOPE 90° BEARING ---

EQUIPMENT Scout 1750 Drill Rig HOLE LOCATION Borehole 3

HOLE SIZE 90mm LOGGED BY HC CHECKED BY NR

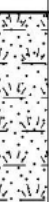
NOTES _____

Method	Samples	Depth (m)	Graphic Log	Classification Symbol	Material Description	Dynamic Cone Penetrometer Blows / 100mm	Additional Observations
Flight Auger & Tungsten Carbide (T.C) Bit	Disturbed Sample LS = 1.0% PI = 2%	0.0			Silty SAND: dark brown	0	TOPSOIL
		0.2		SM	Silty SAND: with gravel: brown: slightly moist: very loose to medium dense: low plasticity	2	RESIDUAL
		1.4		SM	Silty SAND: trace gravel: orange: slightly moist: very dense: low plasticity	32	RESIDUAL
Borehole 3 terminated at 1.5m							

BOREHOLE / TEST PIT WITH DCP 38356-G03A.GPJ GINT STD AUSTRALIA.GDT 12/4/22

Material Test Report

Report Number: 38356-1
Issue Number: 1
Date Issued: 05/04/2022
Client: Ivan Perick
219 Lowes Peak Road, St Fillans NSW 2850
Contact: Ivan Perick
Project Number: 38356
Project Name: Site Classification & Septic Design
Project Location: 219 Lowes Peak Road, St Fillans NSW
Work Request: 6173
Sample Number: D22-6173A
Date Sampled: 09/03/2022
Dates Tested: 09/03/2022 - 29/03/2022
Sampling Method: AS 1289.1.2.1 6.5.3 - Power auger drilling
Site Selection: Selected by Client
Sample Location: **Borehole 1, Depth: 800mm**
Material: Brown Silty SAND With Gravel

barnson.

Barnson Pty Ltd
Dubbo Laboratory

16 L Yarrandale Road Dubbo NSW 2830

Phone: 1300 BARNSON

Email: nreardon@barnson.com.au

Accredited for compliance with ISO/IEC 17025 - Testing



Approved Signatory: Nick Reardon

Laboratory Manager

NATA Accredited Laboratory Number: 9605

Linear Shrinkage (AS1289 3.4.1)		Min	Max
Sample History	Oven Dried		
Preparation Method	Dry Sieve		
Moisture Condition Determined By	AS 1289.3.1.2		
Linear Shrinkage (%)	1.0		
Cracking Crumbling Curling	Cracking		

Material Test Report

Report Number: 38356-1
Issue Number: 1
Date Issued: 05/04/2022
Client: Ivan Perick
219 Lowes Peak Road, St Fillans NSW 2850
Contact: Ivan Perick
Project Number: 38356
Project Name: Site Classification & Septic Design
Project Location: 219 Lowes Peak Road, St Fillans NSW
Work Request: 6173
Sample Number: D22-6173B
Date Sampled: 09/03/2022
Dates Tested: 09/03/2022 - 01/04/2022
Sampling Method: AS 1289.1.2.1 6.5.3 - Power auger drilling
Site Selection: Selected by Client
Sample Location: **Borehole 1, Depth: 2.0m**
Material: Orange Silty Sand Trace Gravel

barnson.

Barnson Pty Ltd

Dubbo Laboratory

16 L Yarrandale Road Dubbo NSW 2830

Phone: 1300 BARNSON

Email: nreardon@barnson.com.au

Accredited for compliance with ISO/IEC 17025 - Testing



Approved Signatory: Nick Reardon

Laboratory Manager

NATA Accredited Laboratory Number: 9605

Linear Shrinkage (AS1289 3.4.1)		Min	Max
Sample History	Oven Dried		
Preparation Method	Dry Sieve		
Moisture Condition Determined By	AS 1289.3.1.2		
Linear Shrinkage (%)	6.5		
Cracking Crumbling Curling	None		

Material Test Report

Report Number: 38356-1
Issue Number: 1
Date Issued: 05/04/2022
Client: Ivan Perick
 219 Lowes Peak Road, St Fillans NSW 2850
Contact: Ivan Perick
Project Number: 38356
Project Name: Site Classification & Septic Design
Project Location: 219 Lowes Peak Road, St Fillans NSW
Work Request: 6173
Sample Number: D22-6173C
Date Sampled: 09/03/2022
Dates Tested: 09/03/2022 - 01/04/2022
Sampling Method: AS 1289.1.2.1 6.5.3 - Power auger drilling
Site Selection: Selected by Client
Sample Location: **Borehole 3, Depth: 800mm**
Material: Brown Silty SAND With Gravel

barnson.

Barnson Pty Ltd
 Dubbo Laboratory
 16 L Yarrandale Road Dubbo NSW 2830
 Phone: 1300 BARNSON
 Email: nreardon@barnson.com.au

Accredited for compliance with ISO/IEC 17025 - Testing



Approved Signatory: Nick Reardon
 Laboratory Manager
 NATA Accredited Laboratory Number: 9605

Atterberg Limit (AS1289 3.1.2 & 3.2.1 & 3.3.1)		Min	Max
Sample History	Oven Dried		
Preparation Method	Dry Sieve		
Liquid Limit (%)	17		
Plastic Limit (%)	15		
Plasticity Index (%)	2		

Linear Shrinkage (AS1289 3.4.1)		Min	Max
Moisture Condition Determined By	AS 1289.3.1.2		
Linear Shrinkage (%)	1.0		
Cracking Crumbling Curling	None		

Emerson Class Number of a Soil (AS 1289 3.8.1)		Min	Max
Emerson Class	5		
Soil Description	Brown Silty SAND With Gravel		
Nature of Water	Distilled		
Temperature of Water (°C)	22		

Appendix C - Site Setback Requirements

TABLE R1
GUIDELINES FOR HORIZONTAL AND VERTICAL SETBACK DISTANCES
 (to be used in conjunction with Table R2)

Site feature	Setback distance range (m) (See Note 1)	Site constraint items of specific concern (from Table R2) (see Note 1)
	<i>Horizontal setback distance (m)</i>	
Property boundary	1.5 – 50 (see Note 2)	A, D, J
Buildings/houses	2.0 – > 6 (see Note 3)	A, D, J
Surface water (see Note 4)	15 – 100	A, B, D, E, F, G, J
Bore, well (see Notes 5 and 6)	15 – 50	A, C, H, J
Recreational areas (Children’s play areas, swimming pools and so on) (see Note 7)	3 – 15 (see Notes 8 and 9)	A, E, J
In-ground water tank	4 – 15 (see Note 10)	A, E, J
Retaining wall and Embankments, escarpments, cuttings (see Note 11)	3.0 m or 45° angle from toe of wall (whichever is greatest)	D, G, H
	<i>Vertical setback distance (m)</i>	
Groundwater (see Notes 5, 6, and 12)	0.6 – > 1.5	A, C, F, H, I, J
Hardpan or bedrock	0.5 – ≥ 1.5	A, C, J
NOTES:		
1 The overall setback distance should be commensurate with the level of risk to public health and the environment. For example, the maximum setback distance should be adopted where site/system features are on the high end of the constraint scale. The setback distance should be based on an evaluation of the constraint items and corresponding sensitive features in Table R2 and how these interact to provide a pathway or barrier for wastewater movement.		
2 Subject to local regulatory rules and design by a suitably qualified and experienced person, the separation of a drip line system from an upslope boundary, for slopes greater than 5%, may be reduced to 0.5 m.		

TABLE R1
GUIDELINES FOR HORIZONTAL AND VERTICAL SETBACK DISTANCES
 (to be used in conjunction with Table R2) (continued)

3	Setback distances of less than 3 m from houses are appropriate only where a drip irrigation land application system is being used with low design irrigation rates, where shallow subsurface systems are being used with equivalent low areal loading rates, where the risk of reducing the bearing capacity of the foundation or damaging the structure is low, or where an effective barrier (designed by a suitably qualified and experienced person) can be installed. This may require consent from the regulatory authority.
4	Setback distance from surface water is defined as the areal edge of the land application system to the edge of the water. Where land application areas are planned in a water supply catchment, advice on adequate buffer distances should be sought from the relevant water authority and a hydrogeologist. Surface water, in this case, refers to any fresh water or geothermal water in a river, lake, stream, or wetland that may be permanently or intermittently flowing. Surface water also includes water in the coastal marine area and water in man-made drains, channels, and dams unless these are to specifically divert surface water away from the land application area. Surface water excludes any water in a pipe or tank.
5	Highly permeable stony soils and gravel aquifers potentially allow microorganisms to be readily transported up to hundreds of metres down the gradient of an on-site system (see R3, Table 1 in Pang et al. 2005). Maximum setback distances are recommended where site constraints are identified at the high scale for items A, C, and H. For reading and guidance on setback distances in highly permeable soils and coarse-grained aquifers see R3. As microbial removal is not linear with distance, data extrapolation of experiments should not be relied upon unless the data has been verified in the field. Advice on adequate buffer distances should be sought from the relevant water authority and a hydrogeologist.
6	Setback distances from water supply bores should be reviewed on a case-by-case basis. Distances can depend on many factors including soil type, rainfall, depth and casing of bore, direction of groundwater flow, type of microorganisms, existing quality of receiving waters, and resource value of waters.
7	Where effluent is applied to the surface by covered drip or spray irrigation, the maximum value is recommended.
8	In the case of subsurface application of primary treated effluent by LPED irrigation, the upper value is recommended.
9	In the case of surface spray, the setback distances are based on a spray plume with a diameter not exceeding 2 m or a plume height not exceeding 0.5 m above finished surface level. The potential for aerosols being carried by the wind also needs to be taken into account.
10	It is recommended that land application of primary treated effluent be down gradient of in-ground water tanks.
11	When determining minimum distances from retaining walls, embankments, or cut slopes, the type of land application system, soil types, and soil layering should also be taken into account to avoid wastewater collecting in the subsoil drains or seepage through cuts and embankments. Where these situations occur setback clearances may need to be increased. In areas where slope stability is of concern, advice from a suitably qualified and experienced person may be required.
12	Groundwater setback distance (depth) assumes unsaturated flow and is defined as the vertical distance from the base of the land application systems to the highest seasonal water table level. To minimise potential for adverse impacts on groundwater quality, minimum setback distances should ensure unsaturated, aerobic conditions in the soil. These minimum depths will vary depending on the scale of site constraints identified in Table R2. Where groundwater setback is insufficient, the ground level can be raised by importing suitable topsoil and improving effluent treatment. The regulatory authority should make the final decision in this instance. (See also the guidance on soil depth and groundwater clearance in Tables K1 and K2.)

TABLE R2
SITE CONSTRAINT SCALE FOR DEVELOPMENT OF SETBACK DISTANCES

(used as a guide in determining appropriate setback distances from ranges given in Table R1)

Item	Site/system feature	Constraint scale (see Note 1)		Sensitive features
		LOWER	HIGHER	
		Examples of constraint factors (see Note 2)		
A	Microbial quality of effluent (see Note 3)	Effluent quality consistently producing ≤ 10 cfu/100 mL <i>E. coli</i> (secondary treated effluent with disinfection)	Effluent quality consistently producing $\geq 10^6$ cfu/100 mL <i>E. coli</i> (for example, primary treated effluent)	Groundwater and surface pollution hazard, public health hazard
B	Surface water (see Note 4)	Category 1 to 3 soils (see Note 5) no surface water down gradient within > 100 m, low rainfall area	Category 4 to 6 soils, permanent surface water <50 m down gradient, high rainfall area, high resource/environmental value (see Note 6)	Surface water pollution hazard for low permeable soils, low lying or poorly draining areas
C	Groundwater	Category 5 and 6 soils, low resource/environmental value	Category 1 and 2 soils, gravel aquifers, high resource/environmental value	Groundwater pollution hazard
D	Slope	0 – 6% (surface effluent application) 0 – 10% (subsurface effluent application)	> 10% (surface effluent application), > 30% subsurface effluent application	Off-site export of effluent, erosion
E	Position of land application area in landscape (see Note 6).	Downgradient of surface water, property boundary, recreational area	Upgradient of surface water, property boundary, recreational area	Surface water pollution hazard, off-site export of effluent
F	Drainage	Category 1 and 2 soils, gently sloping area	Category 6 soils, sites with visible seepage, moisture tolerant vegetation, low lying area	Groundwater pollution hazard
G	Flood potential	Above 1 in 20 year flood contour	Below 1 in 20 year flood contour	Off-site export of effluent, system failure, mechanical faults
H	Geology and soils	Category 3 and 4 soils, low porous regolith, deep, uniform soils	Category 1 and 6 soils, fractured rock, gravel aquifers, highly porous regolith	Groundwater pollution hazard for porous regolith and permeable soils
I	Landform	Hill crests, convex side slopes, and plains	Drainage plains and incise channels	Groundwater pollution hazard, resurfacing hazard
J	Application method	Drip irrigation or subsurface application of effluent	Surface/above ground application of effluent	Off-site export of effluent, surface water pollution

NOTES:

- Scale shows the level of constraint to siting an on-site system due to the constraints identified by SSE evaluator or regulatory authority. See Figures R1 and R2 for examples of on-site system design boundaries and possible site constraints.
- Examples of typical siting constraint factors that may be identified either by SSE evaluator or regulatory authority. Site constraints are not limited to this table. Other site constraints may be identified and taken into consideration when determining setback distances.

TABLE R2
SITE CONSTRAINT SCALE FOR DEVELOPMENT OF SETBACK DISTANCES
 (used as a guide in determining appropriate setback distances from ranges given
 in Table R1) (continued)

3	The level of microbial removal for any on-site treatment system needs to be determined and it should be assumed that unless disinfection is reliably used then the microbial concentrations will be similar to primary treatment. Low risk microbial quality value is based on the values given in ARC (2004), ANZECC and ARMCANZ (2000), and EPA Victoria (<i>Guidelines for environmental management: Use of reclaimed water 2003</i>).
4	Surface water, in this case, refers to any fresh water or geothermal water in a river, lake, stream, or wetland that may be permanently or intermittently flowing. Surface water also includes water in the coastal marine area and water in man-made drains, channels, and dams unless these are to specifically divert surface water away from the land application area. Surface water excludes any water in a pipe or tank.
5	The soil categories 1 to 6 are described in Table 5.1. Surface water or groundwater that has high resource value may include potable (human or animal) water supplies, bores, wells, and water used for recreational purposes. Surface water or groundwater of high environmental value include undisturbed or slightly disturbed aquatic ecosystems as described in ANZECC and ARMCANZ (2000).
6	The regulatory authority may reduce or increase setback distances at their discretion based on the distances of the land application up or downgradient of sensitive receptors.

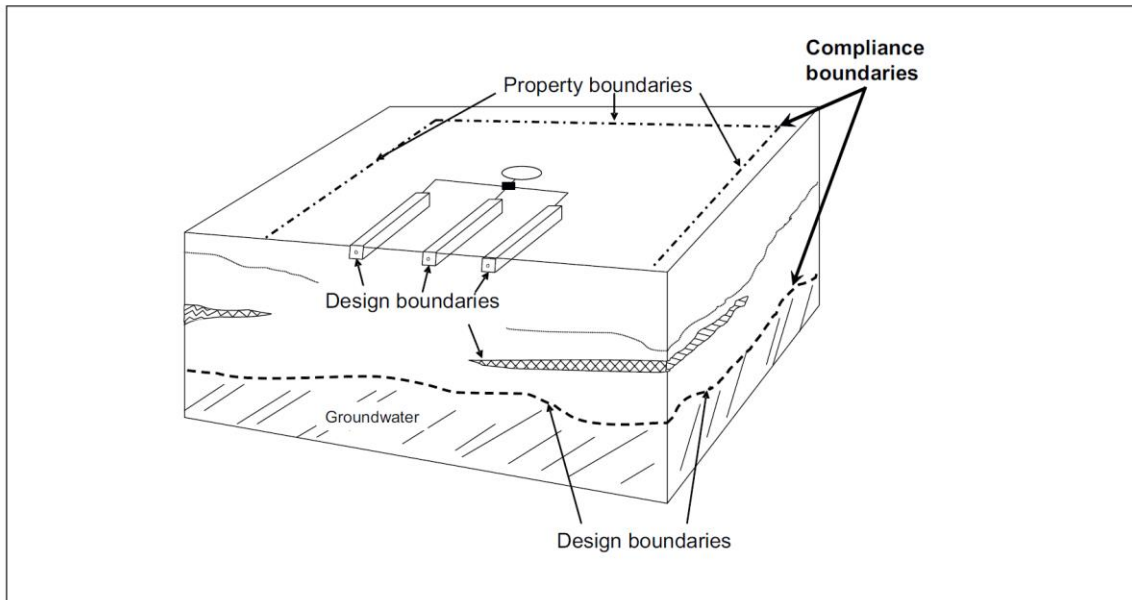

(Adapted from USEPA 2002)

FIGURE R1 EXAMPLE OF DESIGN AND COMPLIANCE BOUNDARIES FOR APPLICATION OF SETBACK DISTANCES FOR A SOIL ABSORPTION SYSTEM

Appendix D - Recommended Species List

APPENDIX 7

VEGETATION SUITABLE FOR LAND APPLICATION AREAS

Botanical Name	Approximate Height	Common Name or Variety
Grasses		
<i>Carex spp.</i>	40 - 80 cm	Available as lawn turf
<i>Lomandra longifolia</i>		
<i>Microlaena stipoides</i>		
<i>Oplismenus imbecillis</i>		
<i>Pennisetum alopecuroides</i>		
<i>Poa lab</i>		
<i>Stipa spp.</i>		
Ground cover/ climbers		
<i>Hibbertia scandens</i>	Prostrate	Snake vine
<i>Hibbertia stellaris</i>		
<i>Isotoma fluviatilis</i>	Climber	Dusky coral pea
<i>Kennedia rubicunda</i>		
<i>Scaevola albida</i>		
<i>Scaevola ramosissima</i>		
<i>Veronica plebeia</i>		
<i>Viola hederacea</i>		Native violet
Sedges/ grasses/ small plants		
<i>Anigozanthus flavidus</i>	2m	Kangaroo Paw
<i>Baumea acuta</i>		
<i>Baumea articulata</i>	Sedge	
<i>Baumea juncea</i>	Sedge	
<i>Baumea nuda</i>	Sedge	
<i>Baumea rubiginosa</i>	Sedge	
<i>Baumea teretifolia</i>	Sedge	
<i>Blandfordia grandiflora</i>	30-90cm	Christmas Bell
<i>Blandfordia nobilis</i>	30-90cm	Christmas Bell
<i>Brachyscome diversifolia</i>	Clump	Native Daisy
<i>Carex appressa</i>	Sedge	
<i>Cotula coronopifolia</i>	10-20cm	Waterbutton
<i>Crinum pedunculatum</i>	<2m	Swamp Lily
<i>Cyperus polystachyos</i>	Sedge	
<i>Dianella caerulea</i>	Low plant	Blue Flax Lily
<i>Epacris microphylla</i>	50cm -1m	
Ferns		
<i>Gahnia spp.</i>	Tall Grass	
<i>Juncus spp.</i>	0.5 m Rush	
<i>Lobelia trigonocaulis</i>	5-10cm	
<i>Lomandra spp.</i>	Grass	
<i>Patersonia fragilis</i>		Native Iris
<i>Patersonia glabrata</i>		Native Iris
<i>Patersonia occidentalis</i>		Native Iris
<i>Ranunculus graniticola</i>	5cm	
<i>Restio australis</i>	Reed	
<i>Restio tetraphyllus</i>	1m	
<i>Sowerbaea juncea</i>	Sedge	Rush Lily
<i>Tetratheca juncea</i>	<30cm	
<i>Xyris operculata</i>	<1m	Tall Yellow Eye

Botanical Name	Approximate Height	Common Name or Variety
Shrubs		
<i>Agonis flexuosa nana</i>		
<i>Baekea linifolia</i>	1 - 2.5 m	
<i>Baekea utilis</i>	1-2.5 m	
<i>Baekea virgata</i>	< 4 m	
<i>Banksia aemula</i>	1 - 7 m	
<i>Banksia robur</i>	0.5 - 2 m	
<i>Bauera ruboides</i>	0.5 - 1.5 m	
<i>Callistemon</i>	2 - 3 m	Burgundy
<i>Callistemon</i>	2 - 4 m	Eureka
<i>Callistemon</i>	3 - 4 m	Harkness
<i>Callistemon</i>	3 - 4.5 m	Kings Park Special
<i>Callistemon</i>	2 - 3 m	Mauve Mist
<i>Callistemon</i>	1 - 2.5 m	Red Clusters
<i>Callistemon</i>	2 - 3 m	Reeves Pink
<i>Callistemon citrinus</i>	50 - 80 cm	Austraflora Firebrand
<i>Callistemon citrinus</i>	2 - 4 m	Splendens
<i>Callistemon citrinus</i>	60cm – 1m	White Ice
<i>Callistemon linearis</i>	1 - 3 m	
<i>Callistemon macropunctatus</i>	2 - 4 m	
<i>Callistemon pachyphyllus</i>	2 - 3 m	
<i>Callistemon pallidus</i>	1.5 - 4 m	
<i>Callistemon paludosus</i>	3 - 7 m	
<i>Callistemon pinifolius</i>	1 - 3 m	
<i>Callistemon rigidus</i>	1.5 - 2.5 m	
<i>Callistemon salignus</i>	3 – 10m	
<i>Callistemon shiresii</i>	4 - 8 m	
<i>Callistemon sieberi</i>	1.5 - 2 m	
<i>Callistemon sieberi</i>	50 - 80 cm	Austraflora Little Cobber
<i>Callistemon subulatus</i>	1 - 2 m	
<i>Callistemon viminalis</i>	1 - 2 m	Captain Cook
<i>Callistemon viminalis</i>	5 - 10 m	Dawson River
<i>Callistemon viminalis</i>	3 - 5 m	Hannah Ray
<i>Callistemon viminalis</i>	50 cm - 1 m	Little John
<i>Callistemon viminalis</i>	1.5 - 2 m	Rose Opal
<i>Callistemon viminalis</i>	2 - 3 m	Western Glory
<i>Goodenia ovata</i>	1 - 1.5 m	
<i>Hibiscus diversifolius</i>	1 - 2 m	Swamp hibiscus
<i>Kunzea capitata</i>	1 - 2 m	
<i>Leptospermum flavescens</i>	< 2 m	Tea-tree
<i>Leptospermum juniperinum</i>	1 m	Tea-tree
<i>Leptospermum lanigerum</i>	1 - 2 m	Woolly tea-tree
<i>Leptospermum squarrosum</i>	< 2 m	Tea-tree
<i>Melaleuca alternifolia</i>	4 - 7 m	
<i>Melaleuca decussata</i>	1 - 2 m	Cross-leaved honey myrtle
<i>Melaleuca lanceolata</i>	4 - 6 m	
<i>Melaleuca squamea</i>	1 - 2 m	
<i>Melaleuca thymifolia</i>		

Botanical Name	Approx Height	Common Name or Variety
Trees		
<i>Acacia elongata</i>	> 2 m	
<i>Acacia floribunda</i>	2 - 4 m	Gossamer wattle
<i>Agonis flexuosa</i>	5 - 6 m	Willow myrtle
<i>Allocasuarina diminuta</i>	1.5 m	
<i>Allocasuarina paludosa</i>	0.5 - 2 m	
<i>Angophora floribunda</i>	Large tree	
<i>Angophora subvelutina</i>	Large tree	
<i>Callicoma serratifolia</i>	< 4m	
<i>Casuarina cunninghamiana</i>	10 - 30 m	River she-oak
<i>Casuarina glauca</i>	6 - 12 m	Swamp oak
<i>Baeocarpus reticulatis</i>	Large tree	Blueberry ash
<i>Eucalyptus amplifolia</i>	Large tree	
<i>Eucalyptus botryoides (coastal areas)</i>	10 - 30 m	
<i>Eucalyptus camaldulensis (west of ranges)</i>	15 - 20 m	River red gum
<i>Eucalyptus deanei</i>	Large tree	Blue Mountains blue gum
<i>Eucalyptus elata</i>	Large tree	River Peppermint
<i>Eucalyptus grandis</i>	10 - 20 m	Flooded gum
<i>Eucalyptus longifolia</i>	20 m	Woollybutt
<i>Eucalyptus pilularis</i>	30 - 40 m	Blackbutt
<i>Eucalyptus punctata</i>	< 35 m	Greygum
<i>Eucalyptus robusta</i>	20 - 30 m	Swamp mahogany
<i>Eucalyptus saligna (coastal)</i>	30 - 50 m	Sydney blue gum
<i>Eucalyptus tereticornis</i>	30 - 40 m	Forest red gum
<i>Eucalyptus viminalis (ranges)</i>	20 - 40 m	Ribbon gum
<i>Acmena smithii</i>	10 - 20 m	Lilli pilli
<i>Flindersia australis</i>	< 40 m	Native teak
<i>Hymenosporum flavuum</i>	3 - 6 m	Native frangipani
<i>Melaleuca armillaris</i>	3 - 4 m	Bracelet honey myrtle
<i>Melaleuca decora</i>	4 - 7 m	
<i>Melaleuca ericifolia</i>	6 m	
<i>Melaleuca halmaturorum</i>	4 - 6 m	
<i>Melaleuca hypericifolia</i>	2 - 3 m	
<i>Melaleuca linariifolia</i>	4 - 8 m	Snow in summer
<i>Melaleuca quinquenervia</i>	5 - 7 m	Broad paperbark
<i>Melaleuca squarrosa</i>	6 m	
<i>Melaleuca stypheloides</i>	6 - 15 m	
<i>Melia azedarach</i>	15 - 20 m	
<i>Pittosporum spp.</i>		
<i>Syzygium paniculatum</i>	8 - 10 m	Bush cherry
<i>Tristania laurina</i>	5 - 15 m	Kanuka
<i>Viminaria juncea</i>	2 - 3 m	Golden spray

Source: Australian Plants Society

Appendix E - Concept Design Sketches - Irrigation System

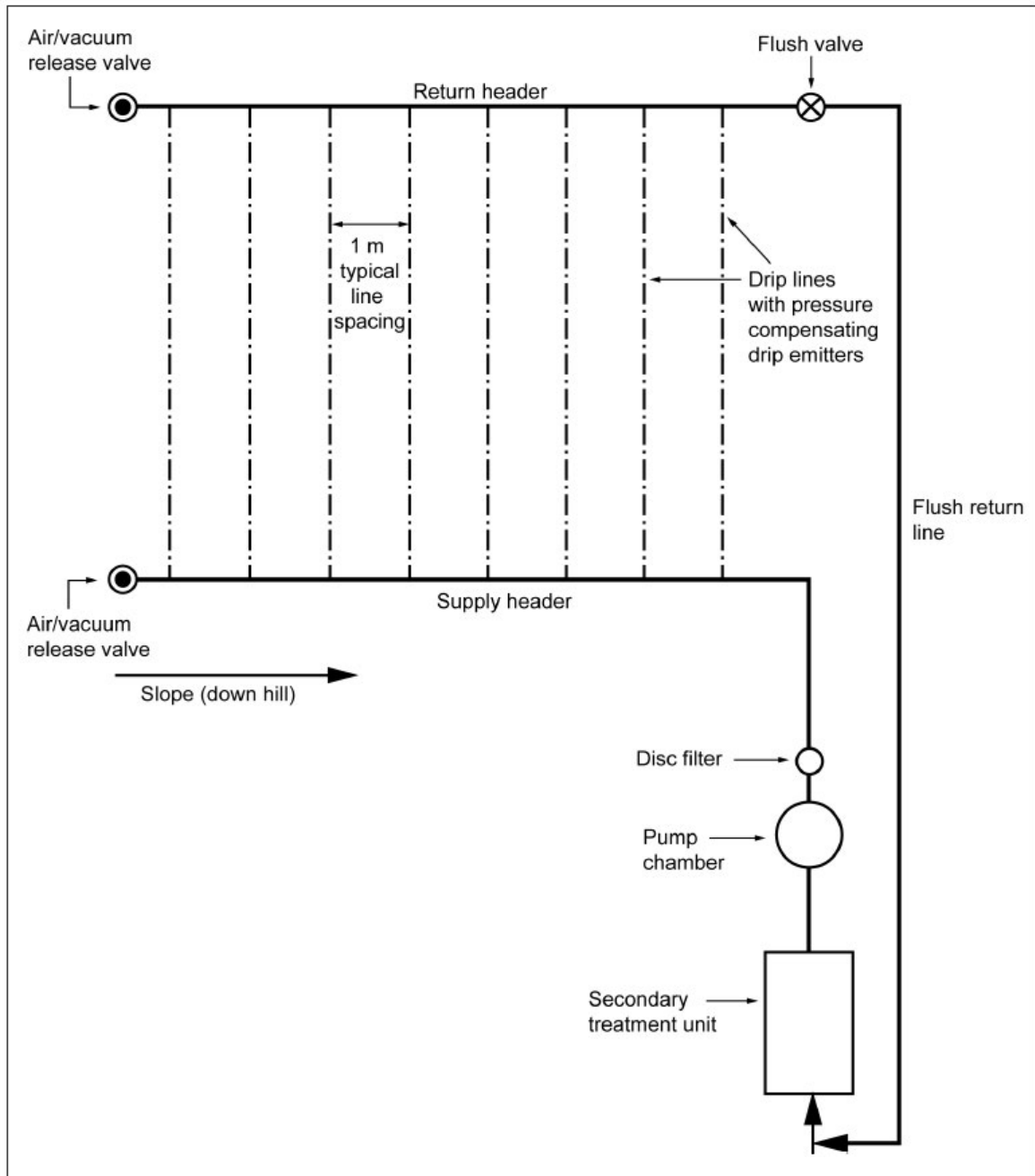

FIGURE M1 DRIP IRRIGATION SYSTEM – EXAMPLE LAYOUT OF COMPONENTS

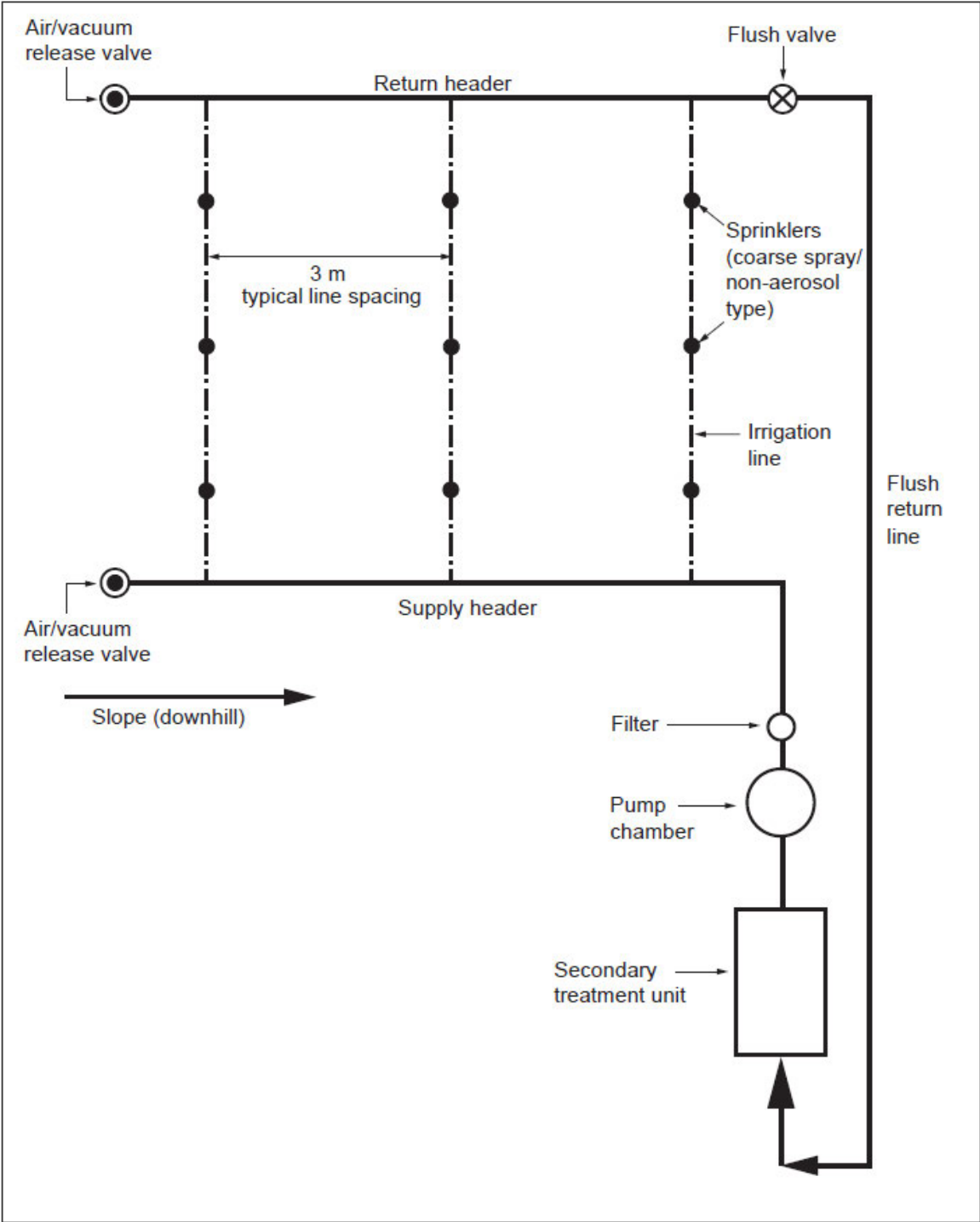
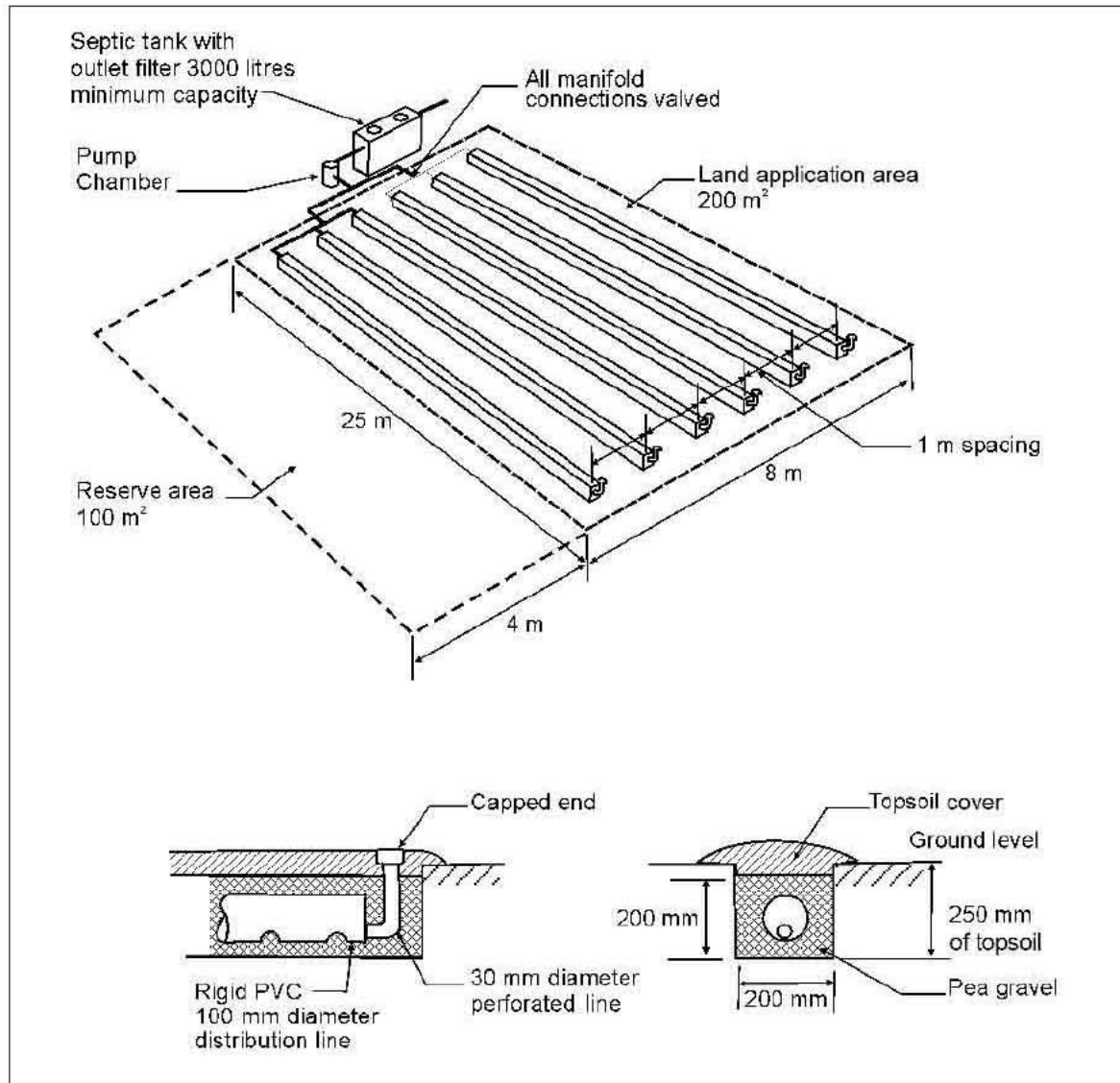

FIGURE M2 SPRAY IRRIGATION SYSTEM – EXAMPLE LAYOUT OF COMPONENTS



NOTES:

- 1 Example system sized for 700 L/d and DIR of 3.5 mm/d in soil Category 3 (see Table M1).
- 2 Preferred dosing method is by a 6-way automatic sequencing valve.
- 3 Good quality topsoil to 250 mm depth is required.
- 4 Flexible 100 mm diameter corrugated drainage line can be used in place of rigid PVC.
- 5 Distribution aggregate of 10 mm to 15 mm size can be used in place of pea gravel.

FIGURE M3 SHALLOW SUBSURFACE LPED IRRIGATION – EXAMPLE SYSTEM

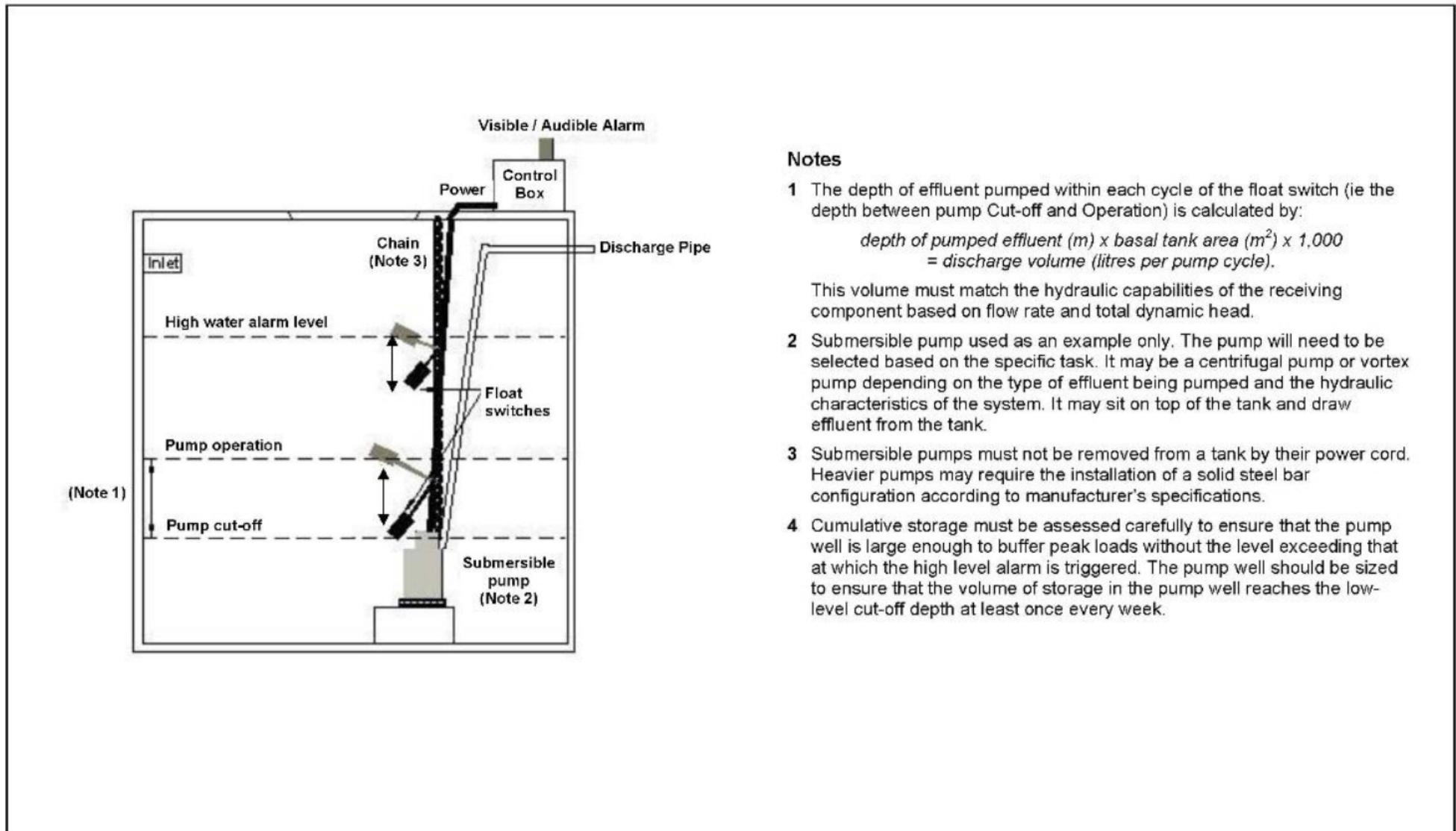

Standard Drawing 12B - Demand Dose Pump well

(not to scale)

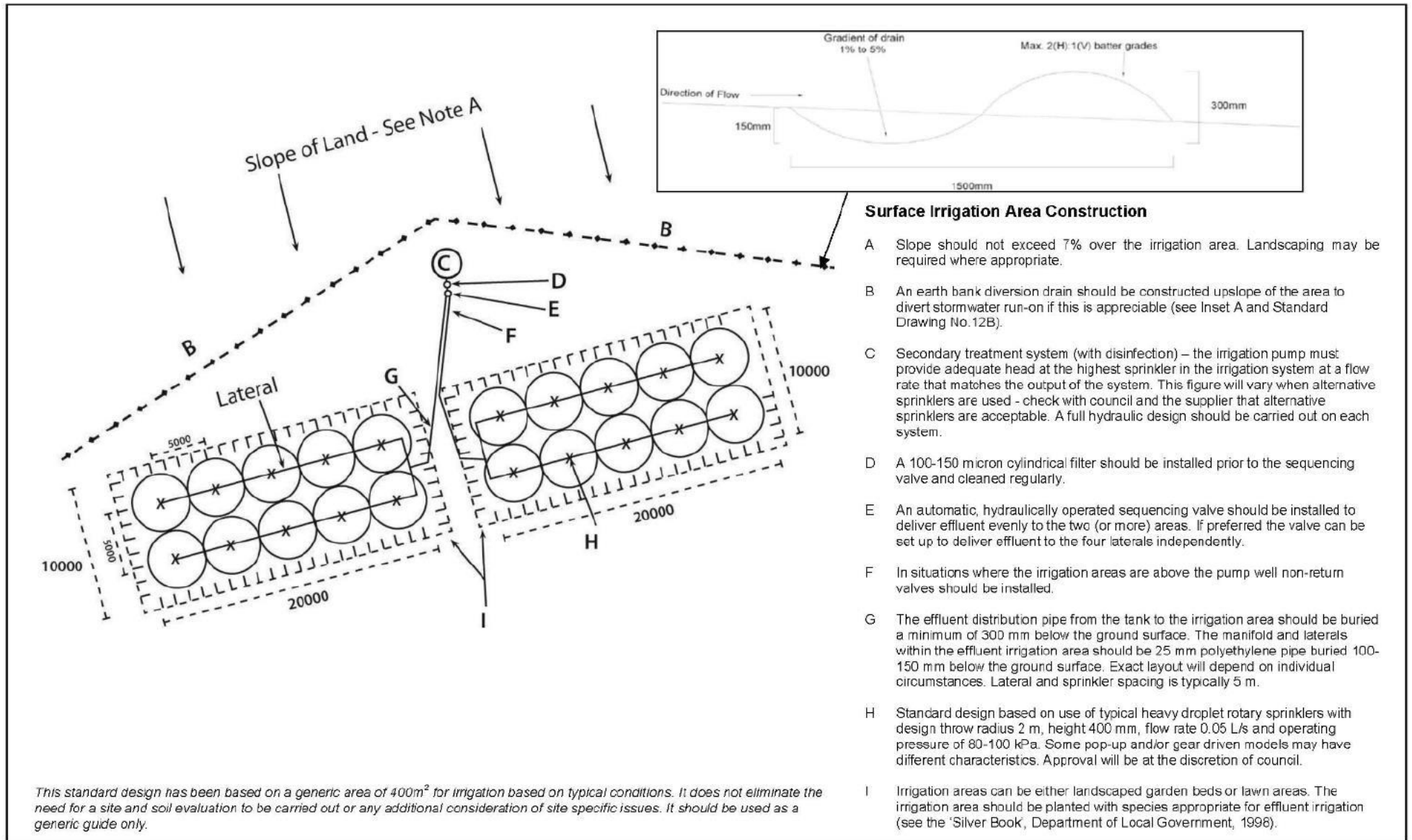

Standard Drawing 12C - Surface Irrigation of Effluent
(not to scale)

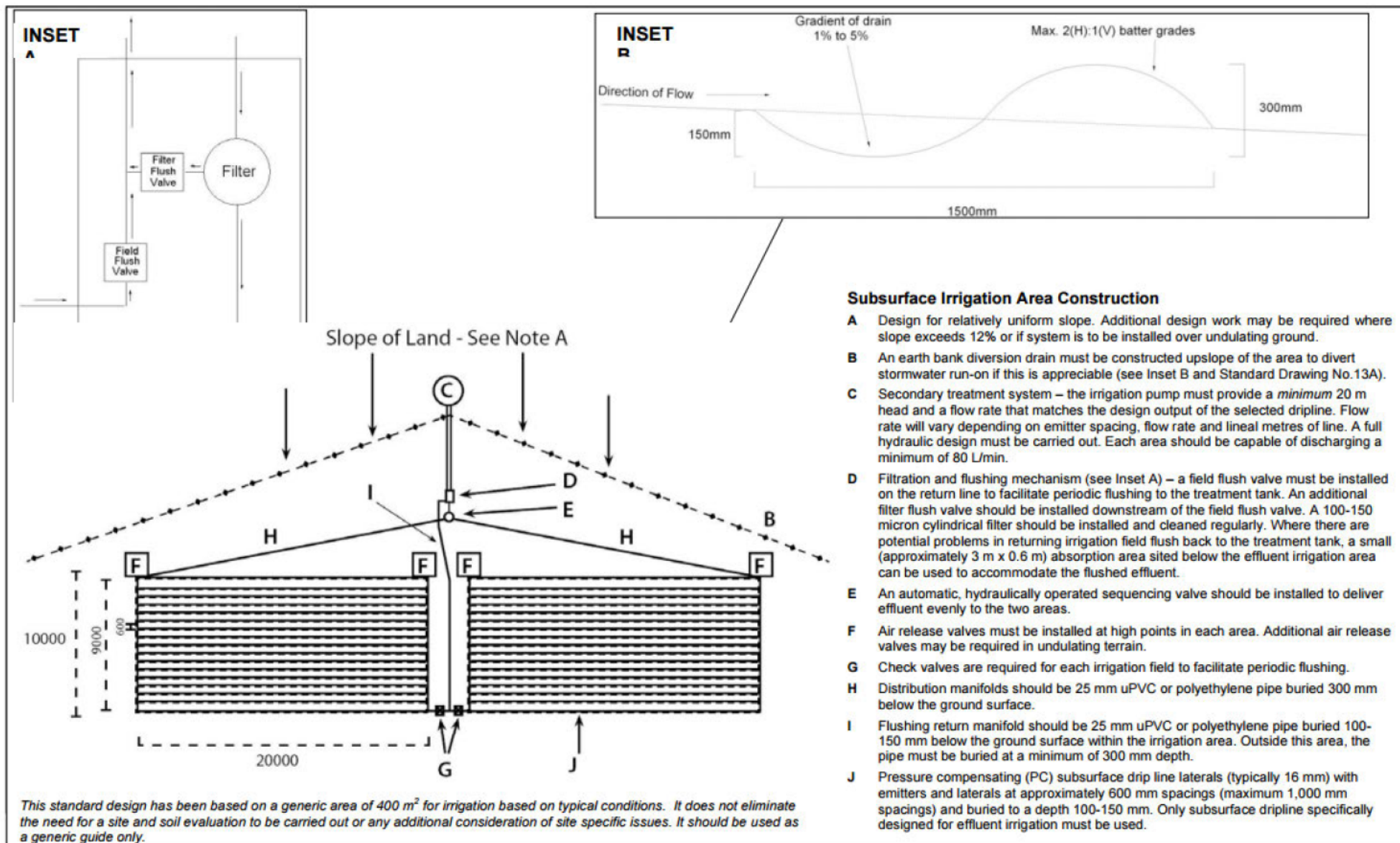

Standard Drawing 13B - Subsurface Effluent Irrigation

(not to scale)

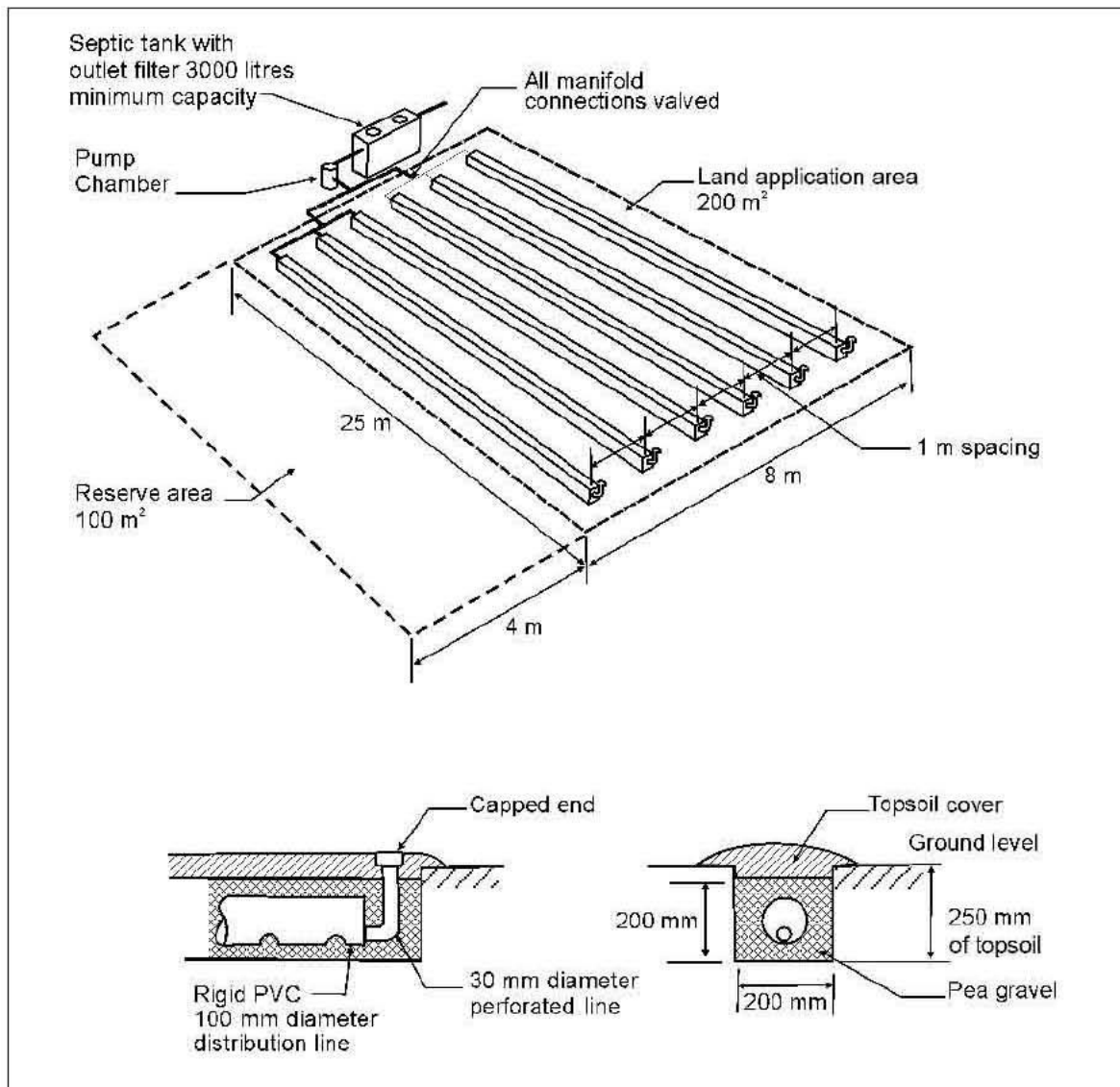

NOTES:

- 1 Example system sized for 700 L/d and DIR of 3.5 mm/d in soil Category 3 (see Table M1).
- 2 Preferred dosing method is by a 6-way automatic sequencing valve.
- 3 Good quality topsoil to 250 mm depth is required.
- 4 Flexible 100 mm diameter corrugated drainage line can be used in place of rigid PVC.
- 5 Distribution aggregate of 10 mm to 15 mm size can be used in place of pea gravel.

FIGURE M3 SHALLOW SUBSURFACE LPED IRRIGATION – EXAMPLE SYSTEM



Appendix F - Site Photos



Plate 1 – Overview of proposed site