

GENERAL NOTES

These documents show the general arrangement of the building and include some items not supplied (refer to the quotation for nomination of all items to be provided). All items not nominated therein shall be supplied and installed by others.

The plans provided here are the latest at the time of print. Earlier plans provided may have become outdated due to engineering changes and should not be used. The plans and drawings are extensive and give all the information needed for a competent person to erect the building. The building is not designed to stand up by itself when it is partially complete. Consequently, construction bracing is critical during erection.

The owner has been requested to check off the BOM after the building delivery. You should check that you are able to locate all materials nominated in the BOM. You should also confirm that the length and size (including thickness), nominated in the BOM is what has been provided. Any missing items are the responsibility of the client once correct delivery has been confirmed as per Terms and Conditions of Sale.

DESIGN CRITERIA

These building plans have been prepared to comply with the standards nominated in the engineer's letter. All plans are not to Scale.

ADDITIONAL DOCUMENTATION TO BE SUPPLIED BY PURCHASER/OWNER

The Purchaser/Owner is responsible for:

*Provision of Soils Report for the site and in the building area on which the building is to be erected

*Site Plan and Drainage Plans

*Any other plans not covered by these engineering plans requested by the local Council or the authority

RAINWATER AND DRAINAGE

All Rainwater and drainage designs are the responsibility of the purchaser/owner. Residential gutters and downpipes where supplied are based on average rainfall for the state and may not be sufficient for your building size or usage. Please speak to your building designer or contractor to ensure gutters are fit for purpose.

BUILDING CONSTRUCTION REQUIREMENTS

The Builder and Purchaser are to ensure that all construction is carried out in accordance with the Plans, the Construction Manual and the Bill of Materials (BOM).

It is the responsibility of the builder to ensure that they are familiar with the operational risks and their obligations in carrying out construction work.

The builder must ensure that they have an appropriate Health & Safety Plan (The Plan) compliant with and as required by their local, state and federal regulations. The Plan will need to take into account the site conditions, the size of the building and the experience of the construction personnel. The Plan will, most likely, differ for each project.

The builder must ensure that The Plan is adhered to. Particular attention should be paid to the requirements to ensure that any person working at heights are properly trained and following the requirements as set out by The Plan.

It is recommended that you check with the appropriate authority in your area as to your responsibilities.

TEMPORARY SUPPORT, LIFTING AND SHORING

The design of temporary propping shoring, lifting and support during construction has not been undertaken and is not included in our engagement. This work is the responsibility of the Contractor undertaking the construction of the building.

SLAB DETAILS - GENERAL

Piers

* The minimum size of Piers under the columns and End Wall Mullions are nominated on the Material Specifications Plan. When the slab and piers are poured as one pour, the depth of the pier is to the top of the slab.

* Pier Reinforcement: for any piers over 1100mm, deformed bar to within 100mm of base and minimum 75mm top cover. Minimum side cover 75mm, maximum 100mm. Rod to be caged horizontally at least twice and at a maximum of 300mm spacing. Tie with a minimum of 6mm diameter cage tie. Where pier diameter is less than 450mm diameter, use 4 N12. For diameters equal to and over 450mm, use 4 N16.

Concrete Slab

* Footings and slabs, including internal and edge beams, must be founded on natural soil with a minimum allowable bearing pressure of 100kPa. Design covers soil classifications of A, S, M, H1 or H2 for a class 10a building.

* The footing designs have been calculated with adhesion values of 0kPa, 25kPa and 50kPa for clay soils and dense sand soils only.

* A site specific geotechnical investigation has not been performed. The builder will need to verify the soil type and conditions.

* Site conditions different to those specified require a modified design.

* Sub grade shall be excavated and compacted to a minimum of 100% standard dry density ratio and within 2% of the OMC to comply with AS2159.

* Designs are in accordance with AS 3600:2018

* All concrete to be in accordance with AS 3600:2018. Minimum 25 Mpa, with 80mm slump.

* Concrete should be cured for 7 days before commencing construction of the building.

* Refer to connection details.

* Saw construction joints to be 25mm deep x 5mm wide. Saw cuttings shall take place no later than 24 hours after pouring. Saw construction joints to be placed at a maximum spacing of 6.3m (in both the length and the span). Care should be taken to avoid construction cuts intersecting where any fixing to the slab is to be made.

* Where columns or end wall mullions have been removed, piers are not required.

* End wall mullion spacing may move due to location of openings or doors. Check layout and component position plan, and relocate piers as required.

* The Slab Plan indicates those parts of the slab which are 50mm below main slab/piers.

For Class A, S or M Sites

* Slab thickness to be a minimum of 100mm with SL 72 mesh and 40mm top cover.

* Concrete piers under Roller Doors Jambs to be a minimum size as below: C15015 - 300mm dia x 375mm deep, centered to the C Section

Where heavy traffic is to go through the roller doors, it is recommended that the slab edge should be thickened to 200mm deep by 300mm wide for the length between the mullions. Place an additional section of SL 72 mesh, 50mm from the base in all thickenings.

For Class H1 or H2 Sites

* Slab thickness to be a minimum of 100mm with SL 82 mesh and 40mm top cover.

* Perimeter beams 550mm deep x 300mm wide with Y12 3 bar Trench Mesh to the perimeter of the building.

* Internal beams 550mm deep by 300mm wide with Y12 3 bar Trench Mesh at a max spacing of 4m.

* Concrete piers under Roller Doors Jambs to be a minimum size as below: C15015 - 300mm dia x 500mm deep, centered to the C Section

SHEETED PORTALS AND MULLIONS

All end wall mullions provide critical support to portal frames and cannot be repositioned or removed under any circumstances without engineering approval.

BRACING NOTES

* Refer to Connection Details.

* All Cross Bracing is achieved with 1.2mm Strap G450.

* Cross bracing is to be fixed taut and secured with 14.20 x 22 frame screws at each end, quantity as per connection details.

* Fly bracing to be fixed to the purlins/girts on all mid portal rafters, columns and end wall mullions. Fly bracing is to be fitted to every second purlin/girt, or, on every one, where the spacing between fly braces would exceed the maximum specified below for the relevant column/rafter size:

- C150 - maximum 1800mm spacing
- C200, C250 - maximum 2200mm spacing
- C300 - maximum 2800mm spacing
- C350 - maximum 2800mm spacing
- C400 - maximum 2800mm spacing

Initial measurement is from the haunch of the column/rafter, and from the rafter for any end wall mullions.

* Open bays to have fly bracing fitted to every available girt supporting the header sheets.

* All bracing strap ends to be located as close as practical to structural member's (columns, rafters, mullions) centerline.

Revision	Date	Initial			General Notes	Seller: THE Shed Company Mudgee Name: S & K Lincoln Pty Ltd Phone: (02) 6372 7755 Fax: (02) 6372 7700 Email: mudgeeadmin@theshedcompany.com.au	Apex Engineering Group PTY LTD ACN 632 588 562 MIE Aust. (Registered NER Structural) 5276680 QLD : RPEQ No. 24223; TAS : 185770492; VIC : PE0003848; N.T : 303557ES; Practising Professional Structural & Civil Engineers
			Purchaser Name: Jason Brown				
			Site Address: 13 Robert Jones St Mudgee NSW 2850 Australia				
			Drawing # TMUD240033 - 2	Print Date: 13/08/2024			
					Page 1 of 2 ©Copyright Steelx IP Pty Ltd		

BOLTS

* Unless otherwise nominated, all bolts are grade 4.6

* All tensioned bolts shall be tensioned using the part turn method (refer to AS4100). For the erector, full details are in the construction manual.

ROLLER DOORS

All roller doors are NOT wind rated. All comments regarding roller doors are referenced from inside the building looking out.

OTHER MATERIALS NOTES

* All Sheeting, Flashing and framing screws are Climaseal 3.

* All purlin material has Z350 zinc coating with minimum strength of 450MPa.

Revision	Date	Initial	Purchaser Name: Jason Brown		General Notes	Seller: THE Shed Company Mudgee Name: S & K Lincoln Pty Ltd Phone: (02) 6372 7755 Fax: (02) 6372 7700 Email: mudgeeadmin@theshedcompany.com.au	Apex Engineering Group PTY LTD ACN 632 588 562 MIE Aust. (Registered NER Structural) 5276680 QLD : RPEQ No. 24223; TAS : 185770492; VIC : PE0003848; N.T : 303557ES; Practising Professional Structural & Civil Engineers
			Site Address: 13 Robert Jones St Mudgee NSW 2850 Australia				
			Drawing # TMUD240033 - 2	Print Date: 13/08/2024			

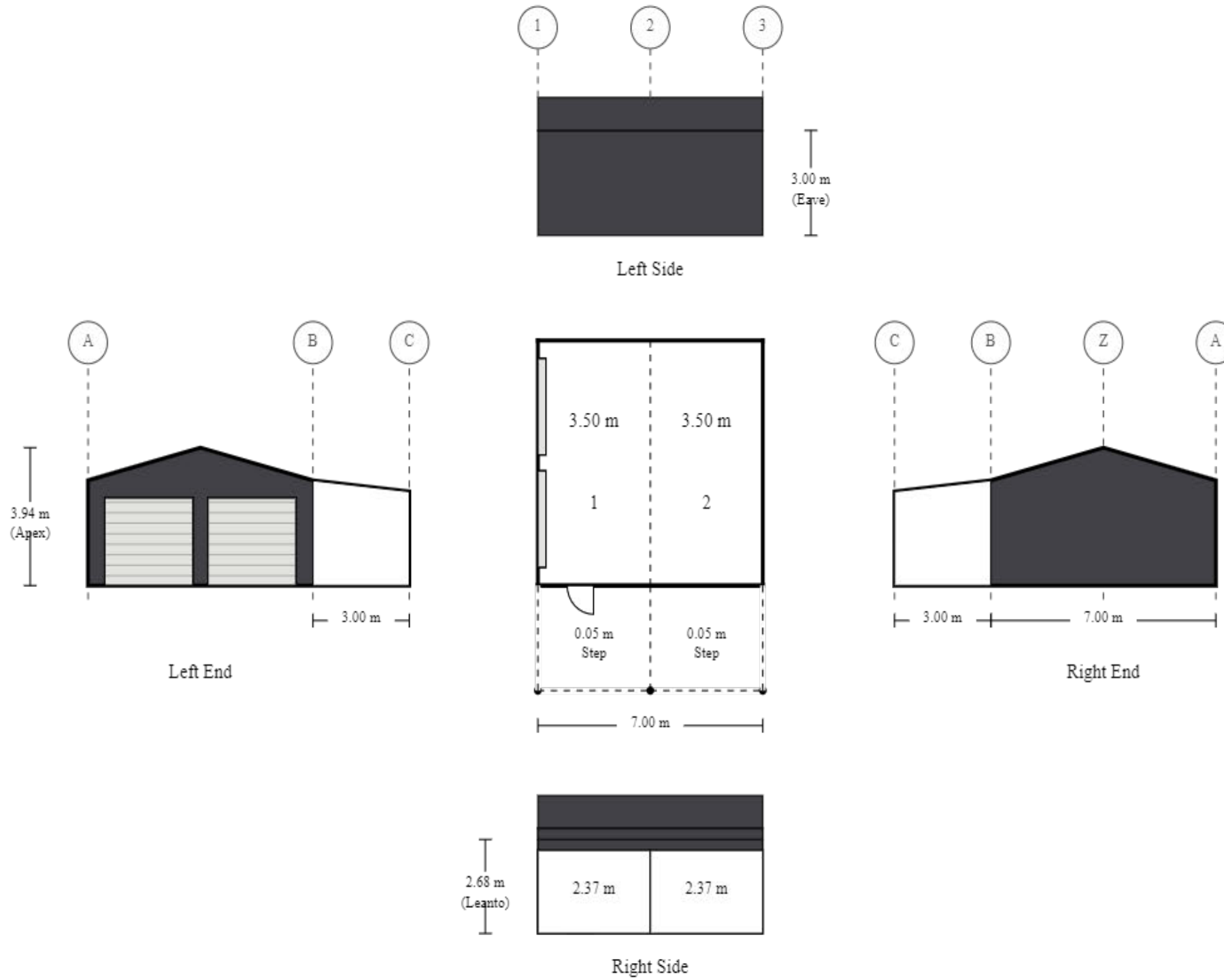

Purchaser Name: Jason Brown

Site Address: 13 Robert Jones St Mudgee NSW 2850 Australia

Drawing # TMJD240033 - 3

Print Date: 13/08/24

Layout
Not to Scale
© Copyright Steelx IP Pty Ltd

Seller: THE Shed Company Mudgee
S & K Lincoln Pty Ltd
Phone: (02) 6372 7755
Fax: (02) 6372 7700
Email: mudgeeadmin@theshedcompany.com.au

Apex Engineering Group PTY LTD
ACN 632 588 562
ME Aust. (Registered NER Structural) 5276680
QLD : RPEQ No. 24223; TAS : 185770492; VIC : PE0003848; N.T. : 303557ES;
Practising Professional Structural & Civil Engineers

MATERIAL SPECIFICATIONS

For further information regarding the tabulated values shown, refer to the General Notes

Building Dimensions

Categories	Span	Length	Pitch	Height	Grid(s)	Portal(s)
Main Building	7 m	7 m	15	3 m	A - B	1 - 3
Right Leanto	3 m	7 m	6	2.68 m	B - C	1 - 3

Portal Frame Elements

Grid / Portal Number		1	2	3
Columns	A	C15012	C15015	C15012
	B	C15012	C15015	C15012
	C	C15012	C15012	C15012
Rafters	A - Apex	C15012	C15015	C15012
	Apex - B	C15012	C15015	C15012
	B - C	C15012	C15012	C15012
End Wall Mullions	Z	-	-	C15012

Bay Section Elements

Bay Number		1	2	Maximum
Bay Widths		3.5 m	3.5 m	
Roof Purlins (refer to Purlin And Girt Plan)		TH64	TH64	
Roof Purlin Spacing (End)	A - Apex	0.89 m	0.89 m	0.9 m
	Apex - B	0.89 m	0.89 m	0.9 m
	B - C	0.9 m	0.9 m	0.9 m
Roof Purlin Spacing (Internal Spans)	A - Apex	0.89 m	0.89 m	1.2 m
	Apex - B	0.89 m	0.89 m	1.2 m
	B - C	1.17 m	1.17 m	1.2 m
Eave Purlin	A	XC15012	XC15012	
	B	XC15012	XC15012	
	C	2XC15012	2XC15012	
Side Girts (refer to Purlin And Girt Plan)		TH64	TH64	
Side Girts Spacing (End)	A	1.38 m	1.38 m	1.7 m
	B	1.38 m	1.38 m	1.7 m
	C	1.7 m	1.7 m	1.7 m
Side Girts Spacing (Internal)	A	1.38 m	1.38 m	1.7 m
	B	1.38 m	1.38 m	1.7 m
	C	1.7 m	1.7 m	1.7 m
PA Door Header	B	C10010	-	
	C	-	-	
PA Door Jamb	B	C10010	-	
	C	-	-	

Revision	Date	Initial			Material Specification Sheet	Seller: THE Shed Company Mudgee Name: S & K Lincoln Pty Ltd Phone: (02) 6372 7755 Fax: (02) 6372 7700 Email: mudgeeadmin@theshedcompany.com.au	Apex Engineering Group PTY LTD ACN 632 588 562 MIE Aust. (Registered NER Structural) 5276680 QLD : RPEQ No. 24223; TAS : 185770492; VIC : PE0003848; N.T : 303557ES; Practising Professional Structural & Civil Engineers
			Purchaser Name: Jason Brown				
			Site Address: 13 Robert Jones St Mudgee NSW 2850 Australia				
			Drawing # TMUD240033 - 4	Print Date: 13/08/2024			

MATERIAL SPECIFICATIONS

For further information regarding the tabulated values shown, refer to the General Notes

End Bay Section Elements

Grid / Portal Number		1	3	Maximum
End Girts (refer to Purlin And Girt Plan)		TH64	TH64	
End Girts Spacing (End)	A - B	1.38 m	-	1.7 m
	B - C	-	-	1.7 m
	A - Z	-	1.38 m	1.7 m
	Z - B	-	1.38 m	1.7 m
End Girts Spacing (Internal)	A - B	1.38 m	-	1.7 m
	B - C	-	-	1.7 m
	A - Z	-	1.38 m	1.7 m
	Z - B	-	1.38 m	1.7 m
Roller Door Header	A - B	HEADER1	-	
	B - C	-	-	
	A - Z	-	-	
	Z - B	-	-	
Roller Door Jambs	A - B	C15015	-	
	B - C	-	-	
	A - Z	-	-	
	Z - B	-	-	

Roller Door

Location - Side & Bay Number	LeftEnd 1	LeftEnd 1
Roller Door Size	2.51x2.75	2.51x2.75
Roller Door Header	HEADER1	HEADER1
Roller Door Jambs	C15015	C15015
Roller Door Clip Config	0 clip	0 clip
Roller Door Manufacturer	CENTURION	CENTURION

PA Door

Location - Side & Bay Number	RightSide 1
PA Door Header	C10010
PA Door Jambs	C10010
PA Door	2.040 x 0.820 - Larnec Shed Door 180° (650.37). Knob/Lever
PA Door Manufacturer	LARNEC

Cladding Elements

Category	Colour	Product
Roof Sheeting	Monument	CORODEK® 0.42 BMT
Roof Flashings	COLORBOND® steel	BlueScope 0.55 BMT
Wall Sheeting	Monument	CORODEK® 0.42 BMT
Wall Flashing	COLORBOND® steel	BlueScope 0.55 BMT

Revision	Date	Initial			Material Specification Sheet Page 2 of 3 ©Copyright Steelx IP Pty Ltd	Seller: THE Shed Company Mudgee Name: S & K Lincoln Pty Ltd Phone: (02) 6372 7755 Fax: (02) 6372 7700 Email: mudgeeadmin@theshedcompany.com.au	Apex Engineering Group PTY LTD ACN 632 588 562 MIE Aust. (Registered NER Structural) 5276680 QLD : RPEQ No. 24223; TAS : 185770492; VIC : PE0003848; N.T : 303557ES; Practising Professional Structural & Civil Engineers
			Purchaser Name: Jason Brown				
			Site Address: 13 Robert Jones St Mudgee NSW 2850 Australia				
			Drawing # TMUD240033 - 4	Print Date: 13/08/2024			

MATERIAL SPECIFICATIONS

For further information regarding the tabulated values shown, refer to the General Notes

Pier Sizes

Adhesion	Soil Description	Diameter	Depth - with Slab			
			BP1	BP2	BP3	BP4
0 kPa	Sandy Soil	0.3 m	0.45 m	0.45 m	0.45 m	0.45 m
		0.45 m	0.45 m	0.45 m	0.45 m	0.45 m
		0.6 m	0.45 m	0.45 m	0.45 m	0.45 m
25 kPa	Soft to Firm Clay	0.3 m	0.45 m	0.45 m	0.45 m	0.45 m
		0.45 m	0.45 m	0.45 m	0.45 m	0.45 m
		0.6 m	0.45 m	0.45 m	0.45 m	0.45 m
50 kPa	Stiff to Very Stiff Clay	0.3 m	0.45 m	0.45 m	0.45 m	0.45 m
		0.45 m	0.45 m	0.45 m	0.45 m	0.45 m
		0.6 m	0.45 m	0.45 m	0.45 m	0.45 m

Revision	Date	Initial	Purchaser Name: Jason Brown		Material Specification Sheet	Seller: THE Shed Company Mudgee Name: S & K Lincoln Pty Ltd Phone: (02) 6372 7755 Fax: (02) 6372 7700 Email: mudgeeadmin@theshedcompany.com.au	Apex Engineering Group PTY LTD ACN 632 588 562 MIE Aust. (Registered NER Structural) 5276680 QLD : RPEQ No. 24223; TAS : 185770492; VIC : PE0003848; N.T : 303557ES; Practising Professional Structural & Civil Engineers
			Site Address: 13 Robert Jones St Mudgee NSW 2850 Australia				
			Drawing # TMUD240033 - 4	Print Date: 13/08/2024			

Cross Bracing is achieved with 1.2mm Strap. Refer to Connection Details.

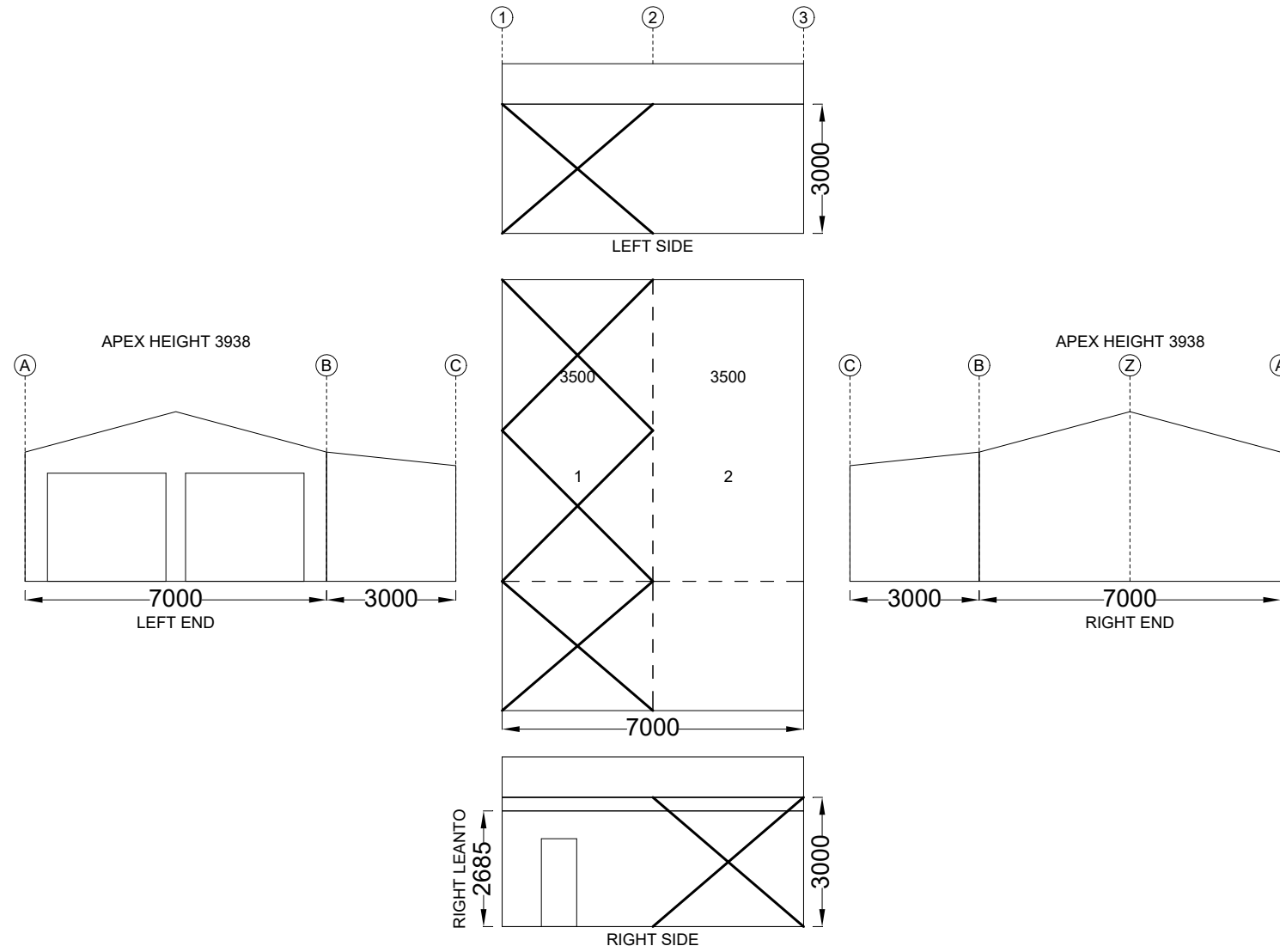

Revision	Date	Initial		
			Purchaser Name: Jason Brown	
			Site Address: 13 Robert Jones St Mudgee NSW 2850 Australia	
			Drawing # TMUD240033 - 5	Print Date: 13/08/2024

Bracing

NOT TO SCALE

Page 1 of 1

©Copyright Steelx IP Pty Ltd

Seller: THE Shed Company Mudgee
 Name: S & K Lincoln Pty Ltd
 Phone: (02) 6372 7755
 Fax: (02) 6372 7700
 Email: mudgeeadmin@theshedcompany.com.au

Apex Engineering Group PTY LTD
 ACN 632 588 562
 MIE Aust. (Registered NER Structural) 5276680
 QLD : RPEQ No. 24223; TAS : 185770492; VIC : PE0003848; N.T : 303557ES;
 Practising Professional Structural & Civil Engineers

These dimensions are provided as a guide only. It is the responsibility of the concreter to confirm that all dimensions are correct.
 Refer to Material Specification Sheet(s) for the Pier Sizes.
 Refer to Slab Plan for concrete stepdowns.

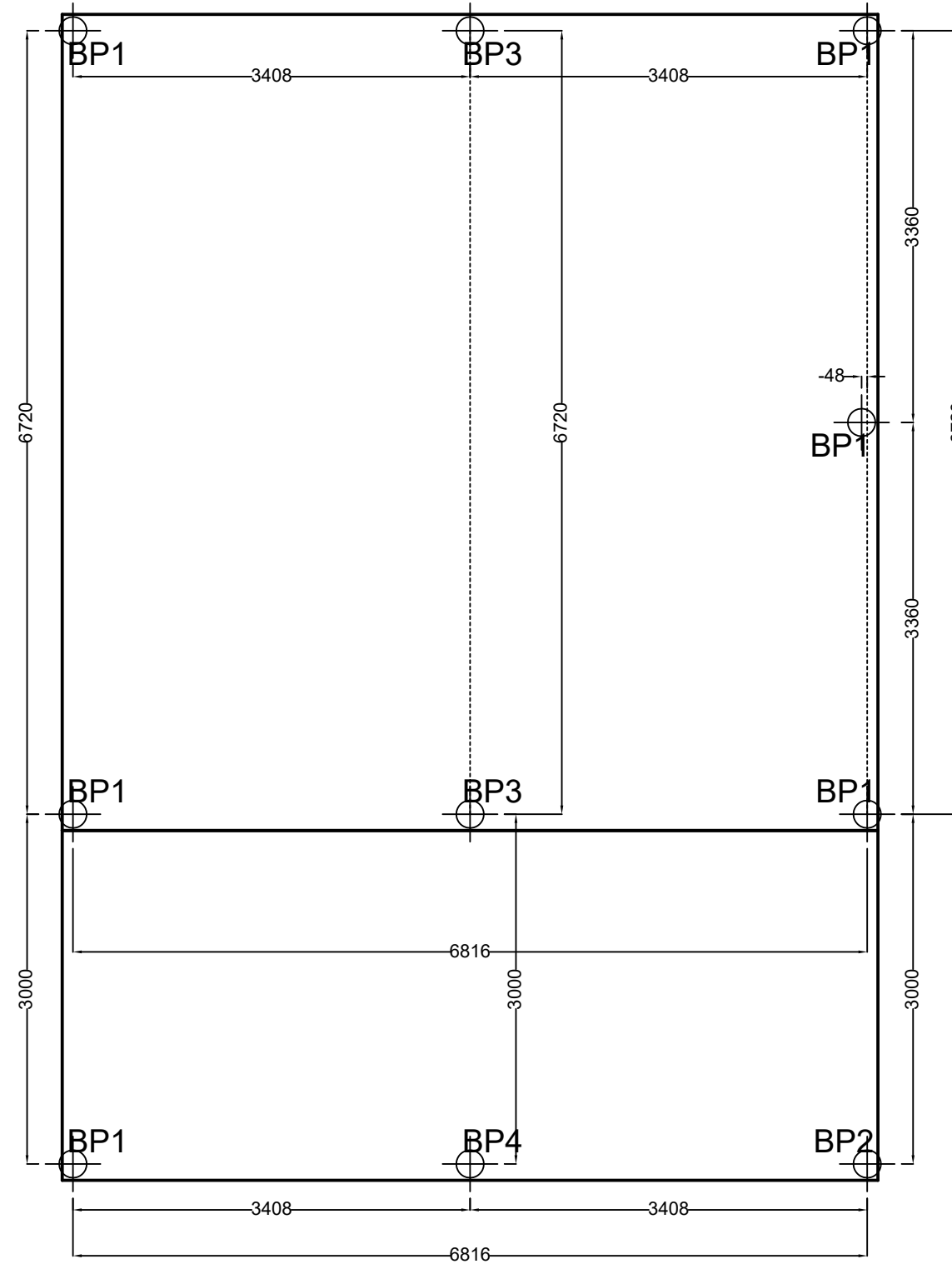

Revision	Date	Initial		
			Purchaser Name: Jason Brown	
			Site Address: 13 Robert Jones St Mudgee NSW 2850 Australia	
			Drawing # TMUD240033 - 6	Print Date: 13/08/2024

Concrete Piers
 PIER MEASUREMENT ONLY
 NOT TO SCALE
 Page 1 of 1
 ©Copyright Steelx IP Pty Ltd

Seller: THE Shed Company Mudgee
 Name: S & K Lincoln Pty Ltd
 Phone: (02) 6372 7755
 Fax: (02) 6372 7700
 Email: mudgeeadmin@theshedcompany.com.au

Apex Engineering Group PTY LTD
 ACN 632 588 562
 MIE Aust. (Registered NER Structural) 5276680
 QLD : RPEQ No. 24223; TAS : 185770492; VIC : PE0003848; N.T : 303557ES;
 Practising Professional Structural & Civil Engineers

These dimensions are provided as a guide only. It is the responsibility of the concreter to confirm that all dimensions are correct.

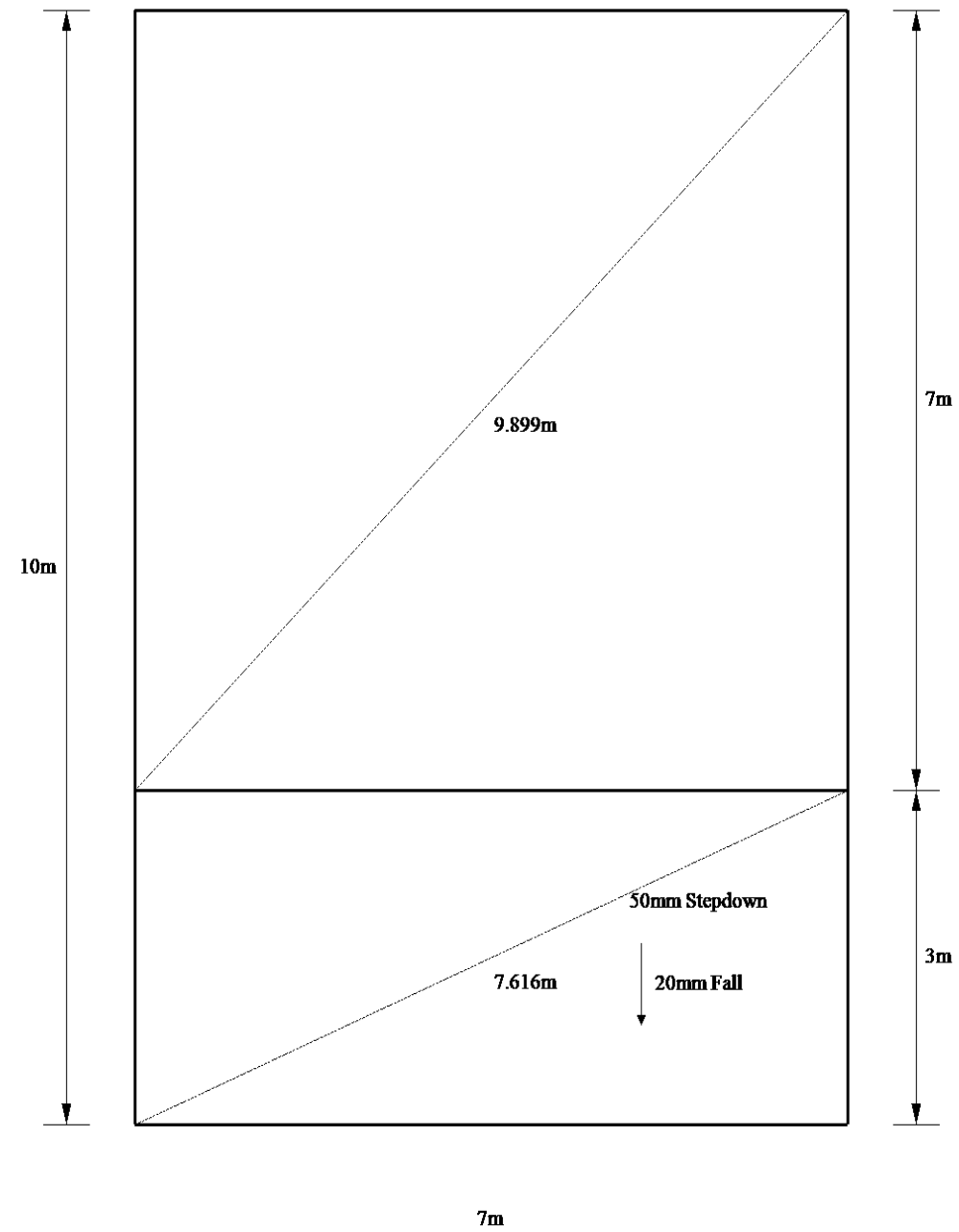

Purchaser Name: Jason Brown

Site Address: 13 Robert Jones St Mudgee NSW 2850 Australia

Drawing # TMJD240033 - 7

Print Date: 13/08/24

Slab Dimensions
Also refer to Concrete Piers Plan
Not to Scale
© Copyright Steelx IP Pty Ltd

Seller: THE Shed Company Mudgee
S & K Lincoln Pty Ltd
Phone: (02) 6372 7755
Fax: (02) 6372 7700
Email: mudgeeadmin@theshedcompany.com.au

Apex Engineering Group PTY LTD
ACN 632 588 562
ME Aust. (Registered NER Structural) 5276680
QLD : RPEQ No. 24223; TAS : 185770492; VIC : PE0003848; N.T. : 303557ES;
Practising Professional Structural & Civil Engineers

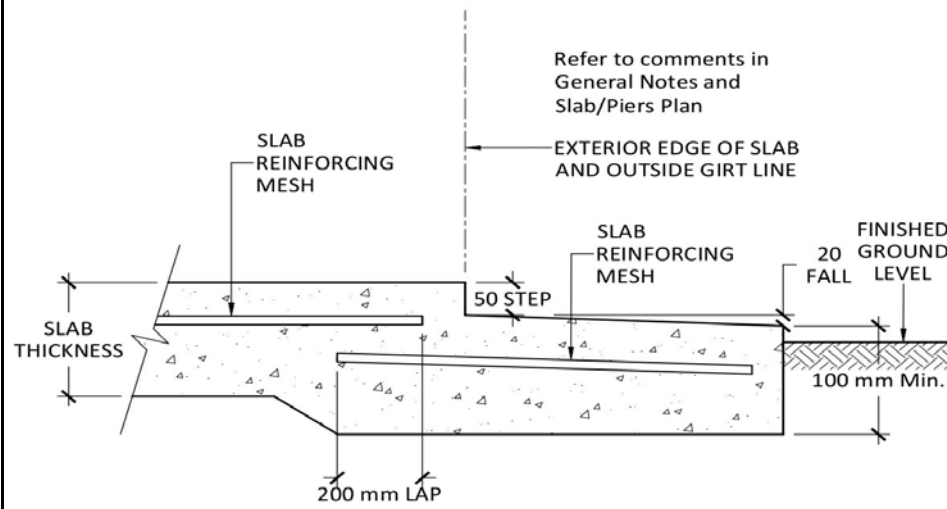

CONCRETE SLAB with 50 mm STEP DOWN

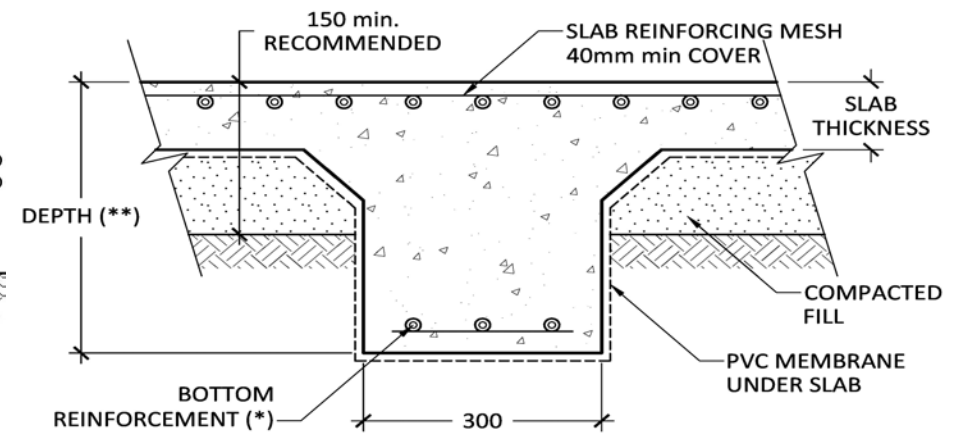

INTERNAL BEAM (H1 & H2 SOIL TYPE, OPTIONAL A, S & M)

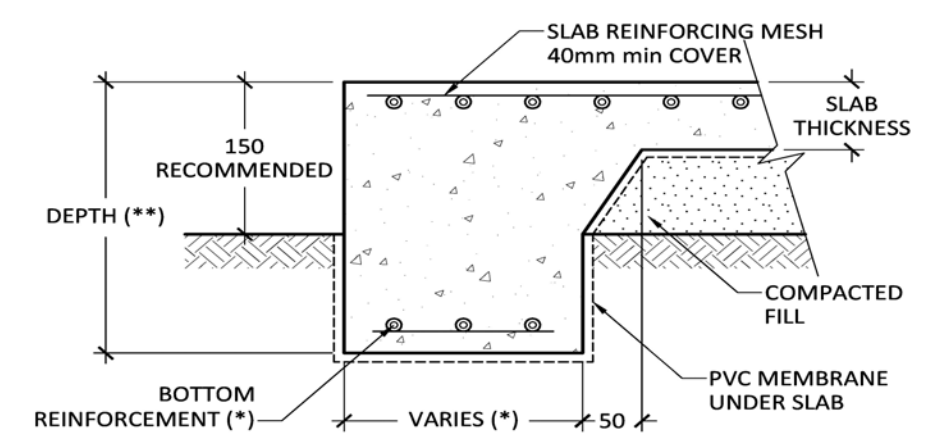

PERIMETER BEAM (H1 & H2 SOIL TYPE, OPTIONAL A, S & M)

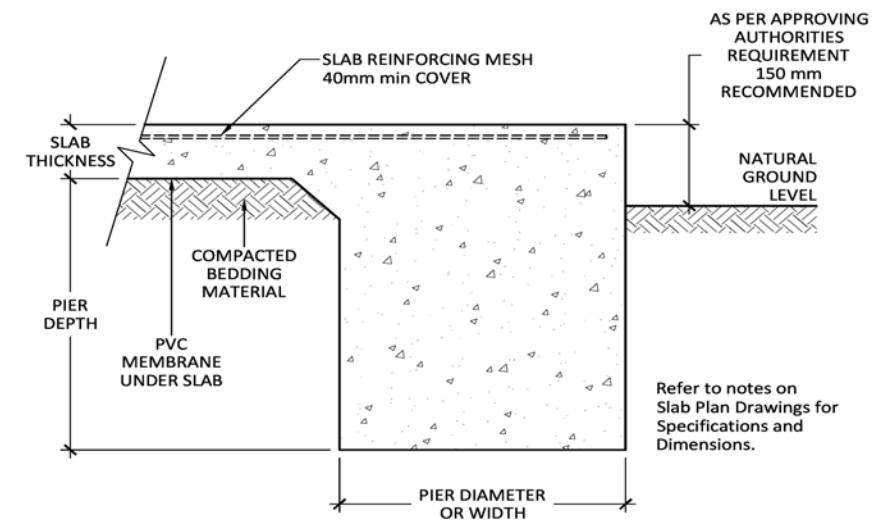
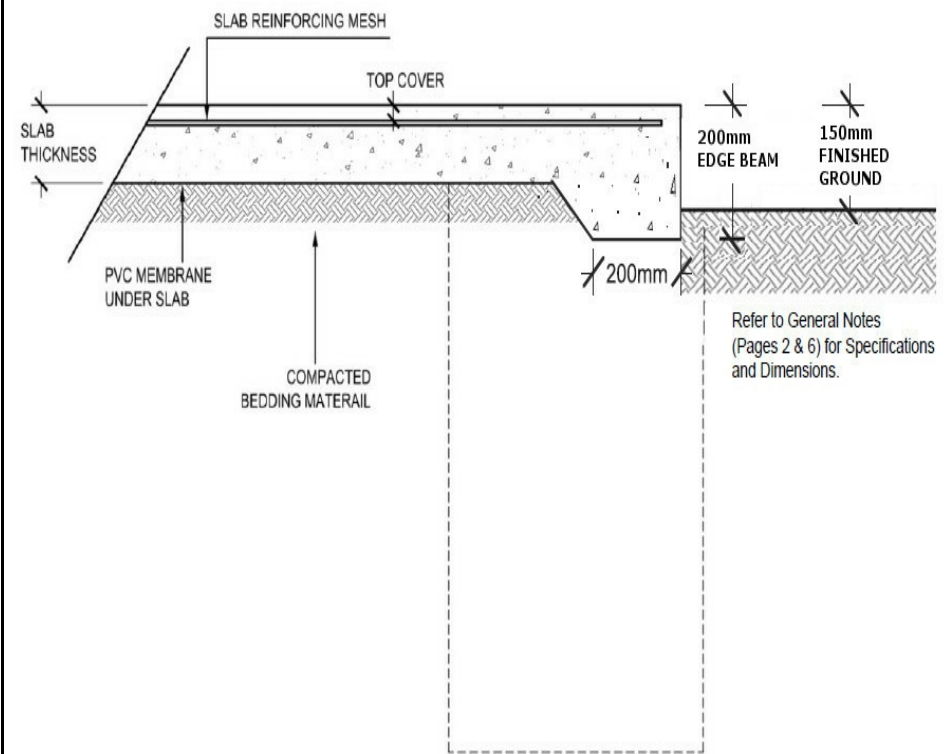

SLAB AND PIER DETAIL

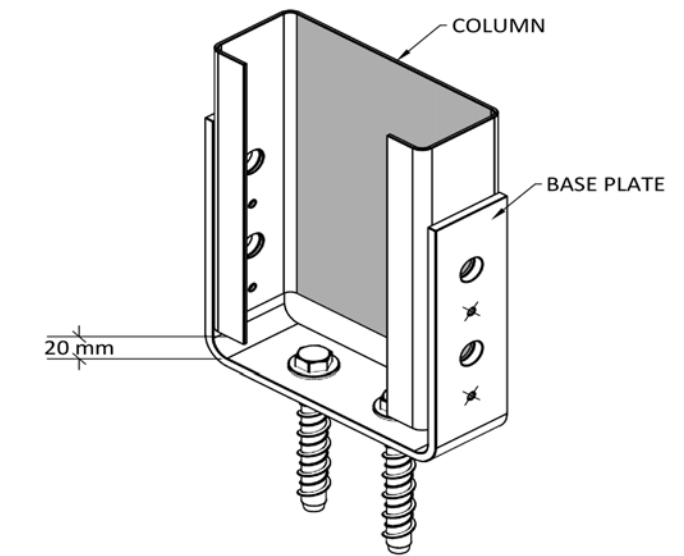

C150 COLUMN FIXING (BF)
 ○ FIXING BOLTS - 2 of M12 x 100 SCREWBOLT
 ○ FIXING BOLTS - 4 of M12 x 30 Galv.
 × FIXING SCREWS - 4 of 12.24 x 38 Series 500

Purchaser Name: Jason Brown

Site Address: 13 Robert Jones St Mudgee NSW 2850 Australia

Drawing # TMJD240033 - 8

Print Date: 13/08/24

Connection Details
 Not to Scale
 Page 1 of 6
 © Copyright Steelx IP Pty Ltd

Seller: THE Shed Company Mudgee
 S & K Lincoln Pty Ltd
 Phone: (02) 6372 7755
 Fax: (02) 6372 7700
 Email: mudgeeadmin@theshedcompany.com.au

Apex Engineering Group PTY LTD
 ACN 632 588 562
 ME Aust. (Registered NER Structural) 5276680
 QLD : RPEQ No. 24223; TAS : 185770492; VIC : PE0003848; N.T : 303557ES;
 Practising Professional Structural & Civil Engineers

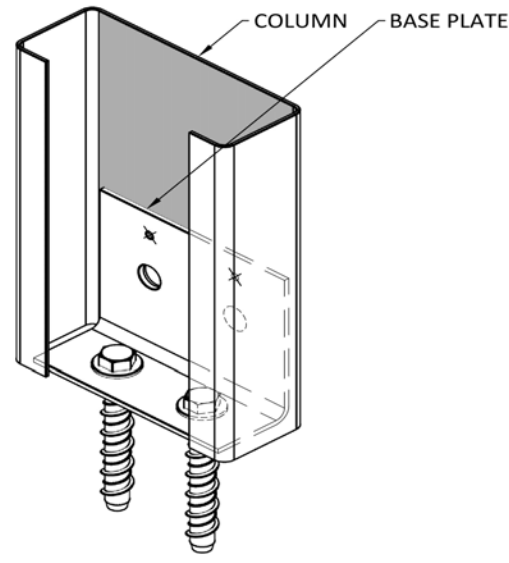

- FIXING BOLTS - 2 of M12 x 100 SCREWBOLTS
- FIXING BOLTS - 2 of M12 x 30 Galv.
- × FIXING SCREWS - 2 of 14.20 x 22

C150 MULLION BASE PLATE (B)

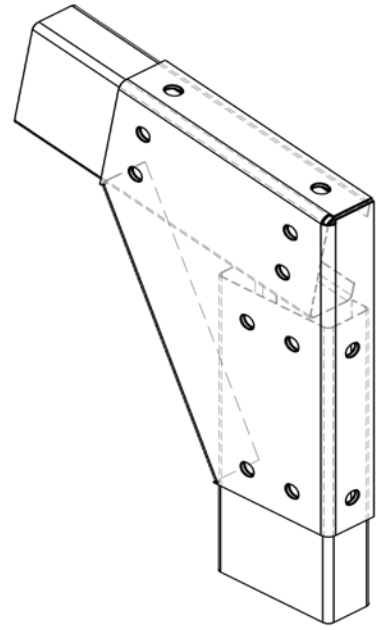

- FIXING BOLTS - 12 of M12 x 30 (8.8)

KNEE HAUNCH BRACKET (HS&HT) - C150, 6°

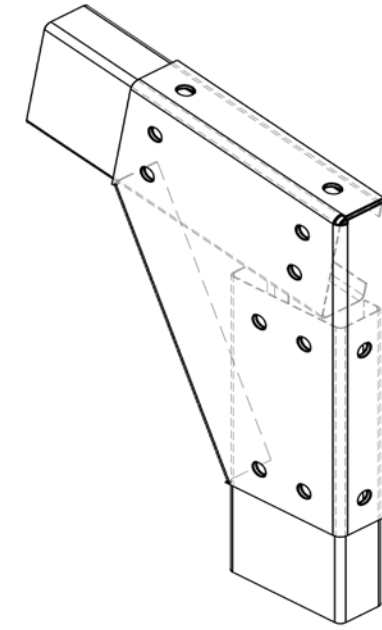

- FIXING BOLTS - 12 of M12 x 30 (8.8)

KNEE HAUNCH BRACKET (HS&HT) - C150, 15°

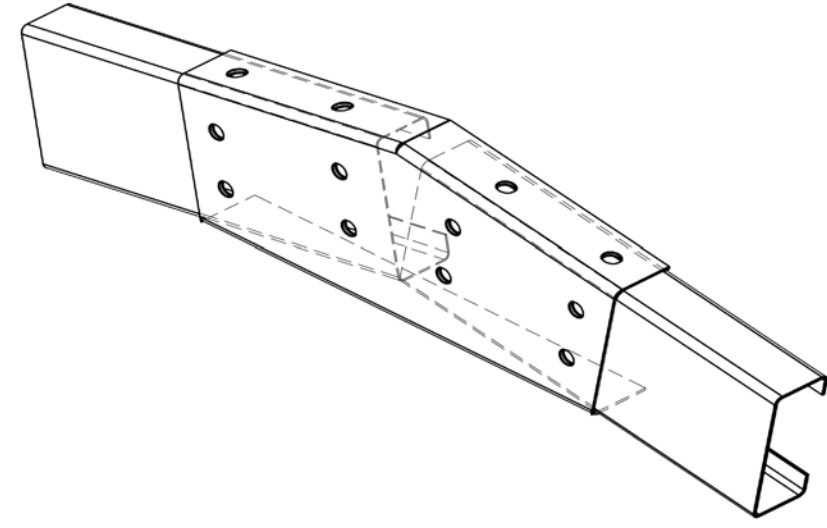

- FIXING BOLTS - 12 of M12 x 30 (8.8)

APEX PLATE (A) - C150, 15°

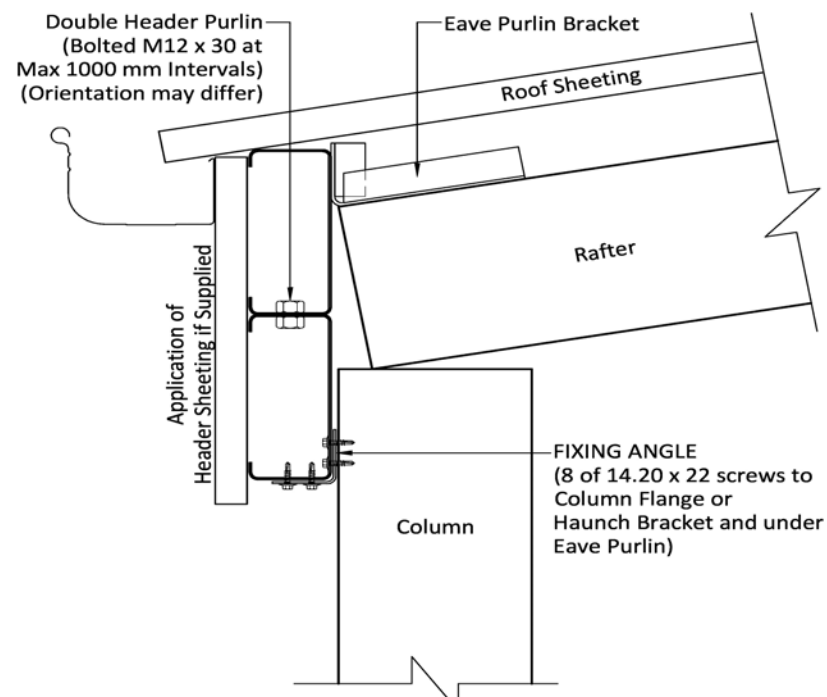

DOUBLE HEADER PURLIN CONNECTION - OPEN BAYS

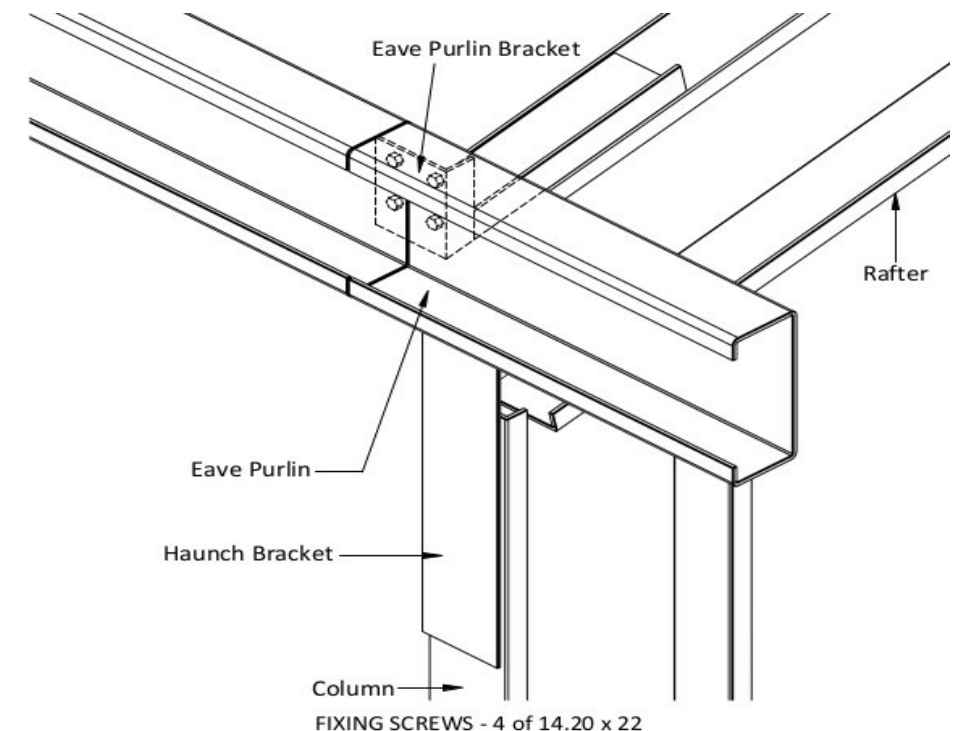

EAVE PURLIN TO EAVE PURLIN BRACKET

Purchaser Name: Jason Brown

Site Address: 13 Robert Jones St Mudgee NSW2850 Australia

Drawing # TMJD240033 - 8

Print Date: 13/08/24

Connection Details

Not to Scale
Page 2 of 6
© Copyright Steelx IP Pty Ltd

Seller: THE Shed Company Mudgee
S & K Lincoln Pty Ltd
Phone: (02) 6372 7755
Fax: (02) 6372 7700
Email: mudgeeadmin@theshedcompany.com.au

Apex Engineering Group PTY LTD
ACN 632 588 562
ME Aust. (Registered NER Structural) 5276680
QLD : RPEQ No. 24223; TAS : 185770492; VIC : PE0003848; N.T. : 303557ES;
Practising Professional Structural & Civil Engineers

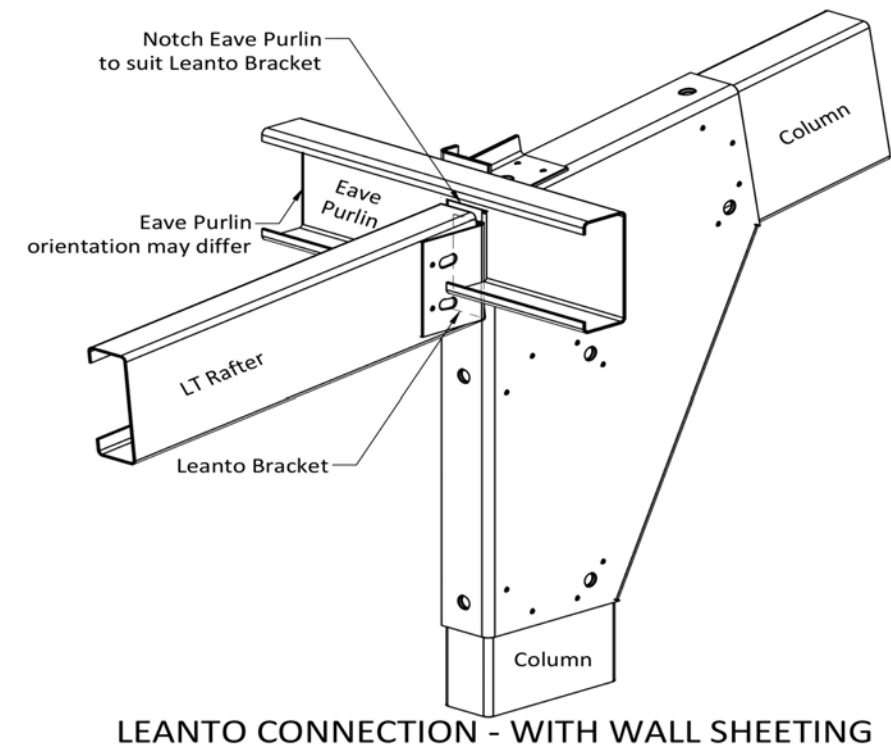
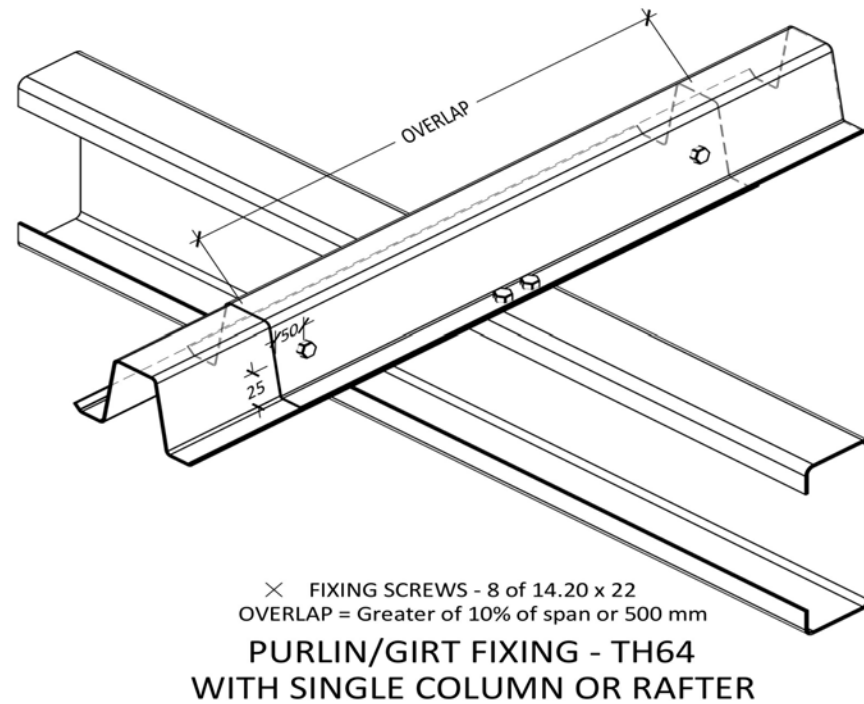
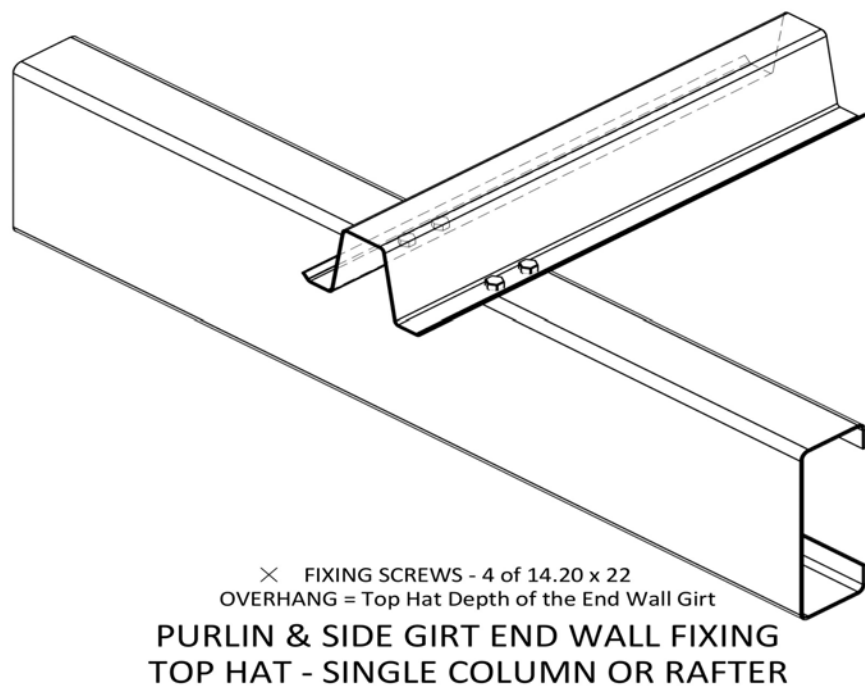
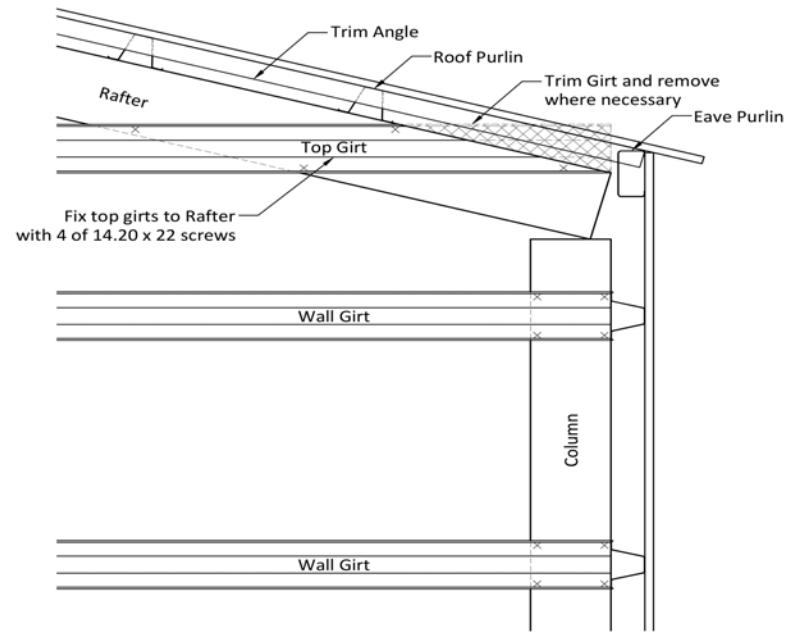
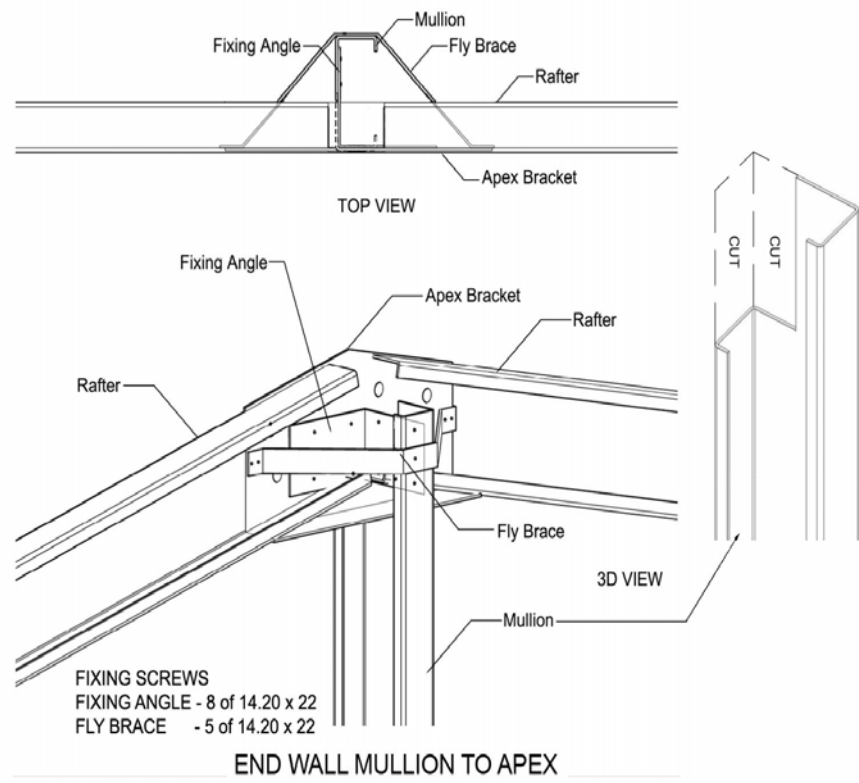

Purchaser Name: Jason Brown

Site Address: 13 Robert Jones St Mudgee NSW 2850 Australia

Drawing # TMJD240033 - 8

Print Date: 13/08/24

Connection Details
 Not to Scale
 Page 3 of 6
 © Copyright SteelX IP Pty Ltd

Seller: THE Shed Company Mudgee
 S & K Lincoln Pty Ltd
 Phone: (02) 6372 7755
 Fax: (02) 6372 7700
 Email: mudgeeadmin@theshedcompany.com.au

Apex Engineering Group PTY LTD
 ACN 632 588 562
 ME Aust. (Registered NER Structural) 5276680
 QLD : RPEQ No. 24223; TAS : 185770492; VIC : PE0003848; N.T : 303557ES;
 Practising Professional Structural & Civil Engineers

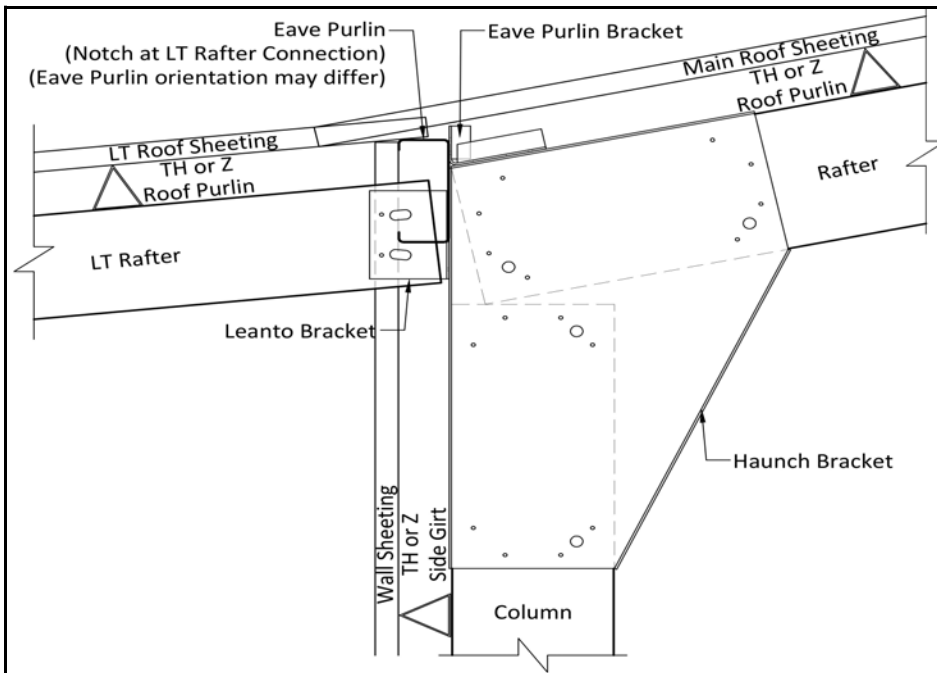

LEANTO CONNECTION - WITH WALL SHEETING

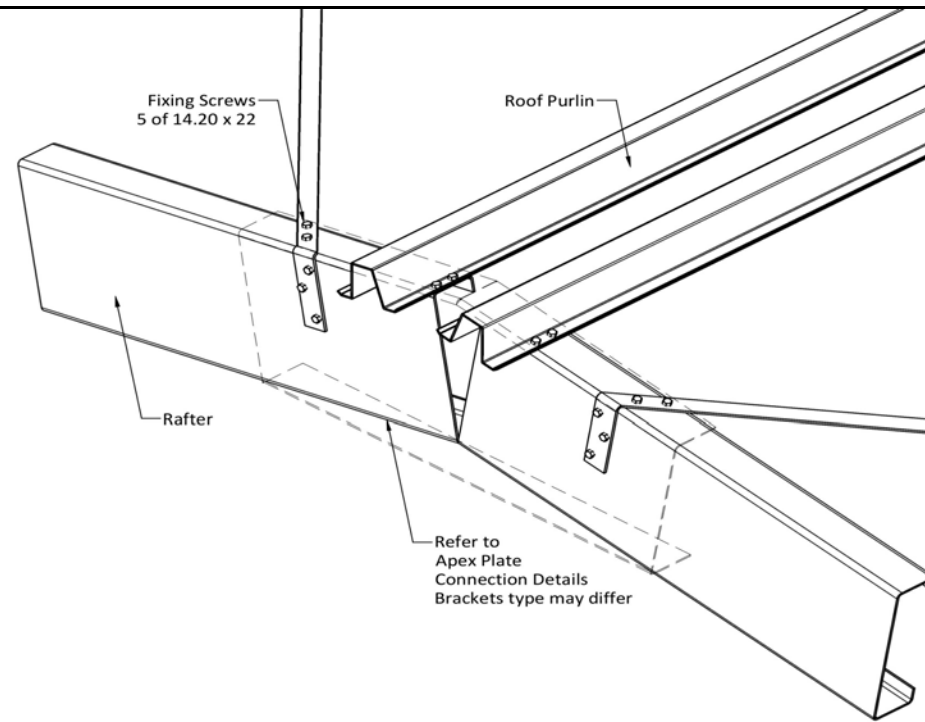

BRACING CONNECTION AT APEX

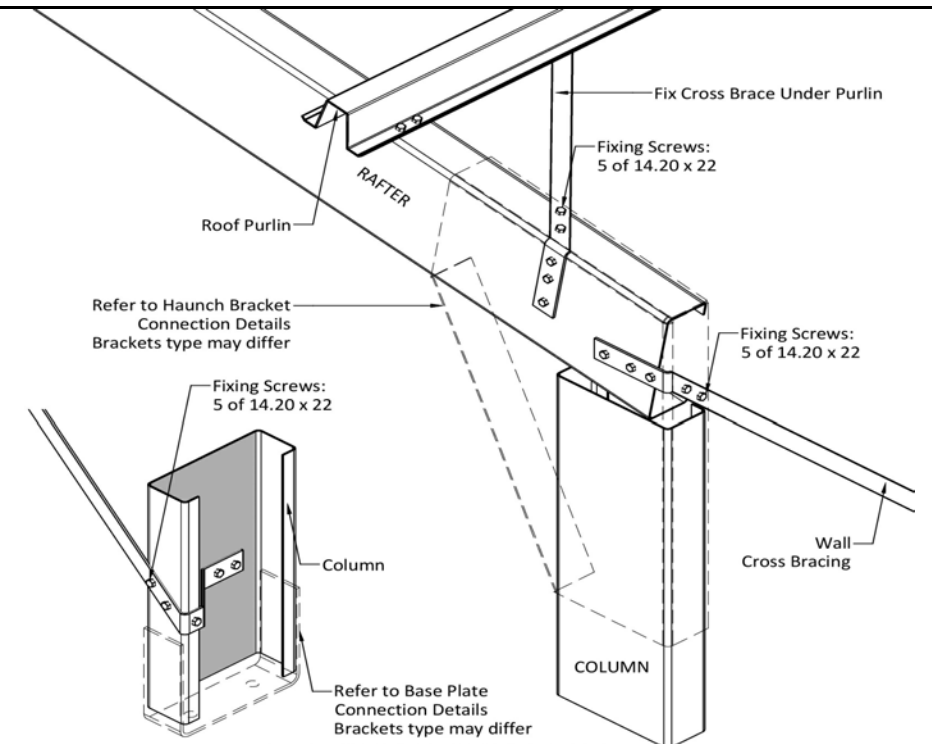

BRACING CONNECTION

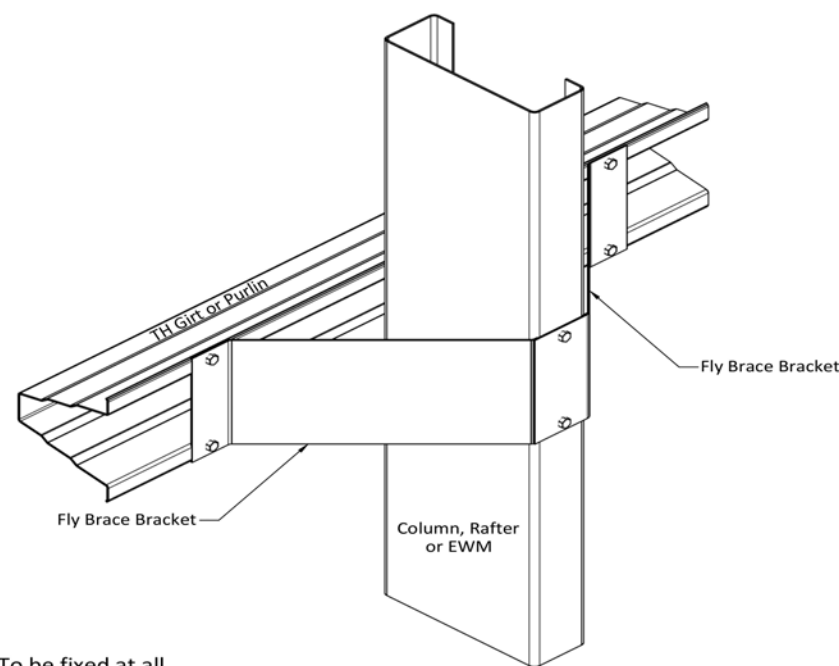

To be fixed at all Columns, Rafters & EWM where possible

FIXING SCREWS - 6 of 14.20 x 22

FLY BRACING BRACKET

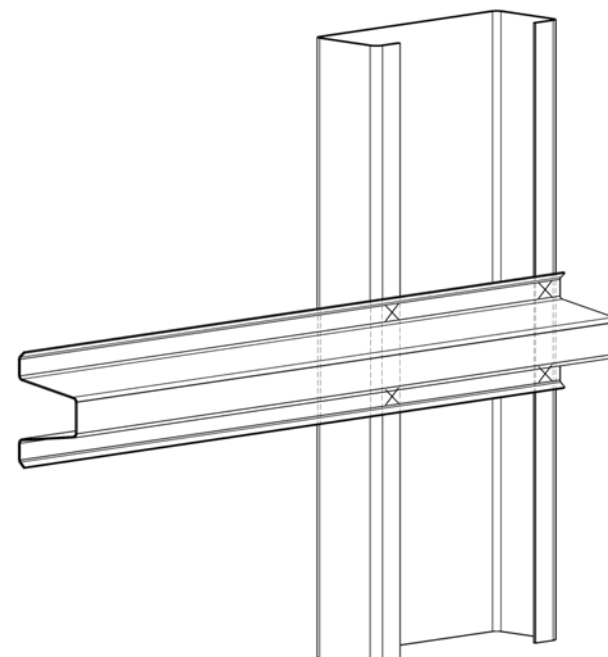

× FIXING SCREWS - 4 of 14.20 x 22

GIRT FIXING TO MULLIONS - TOP HAT

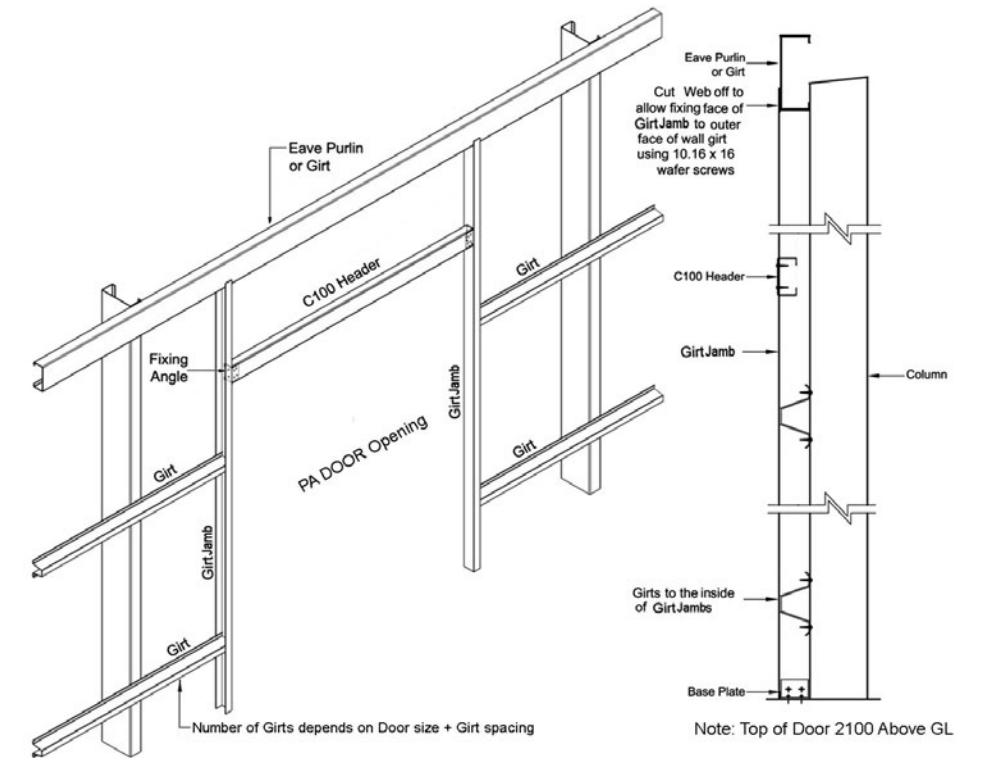

PA DOOR (PRE HUNG) CONNECTION DETAILS

Purchaser Name: Jason Brown

Site Address: 13 Robert Jones St Mudgee NSW 2850 Australia

Drawing # TMJD240033 - 8

Print Date: 13/08/24

Connection Details

Not to Scale
Page 4 of 6
© Copyright Steelx IP Pty Ltd

Seller: THE Shed Company Mudgee
S & K Lincoln Pty Ltd
Phone: (02) 6372 7755
Fax: (02) 6372 7700
Email: mudgeeadmin@theshedcompany.com.au

Apex Engineering Group PTY LTD
ACN 632 588 562
ME Aust. (Registered NER Structural) 5276680
QLD : RPEQ No. 24223; TAS : 185770492; VIC : PE0003848; N.T. : 303557ES;
Practising Professional Structural & Civil Engineers

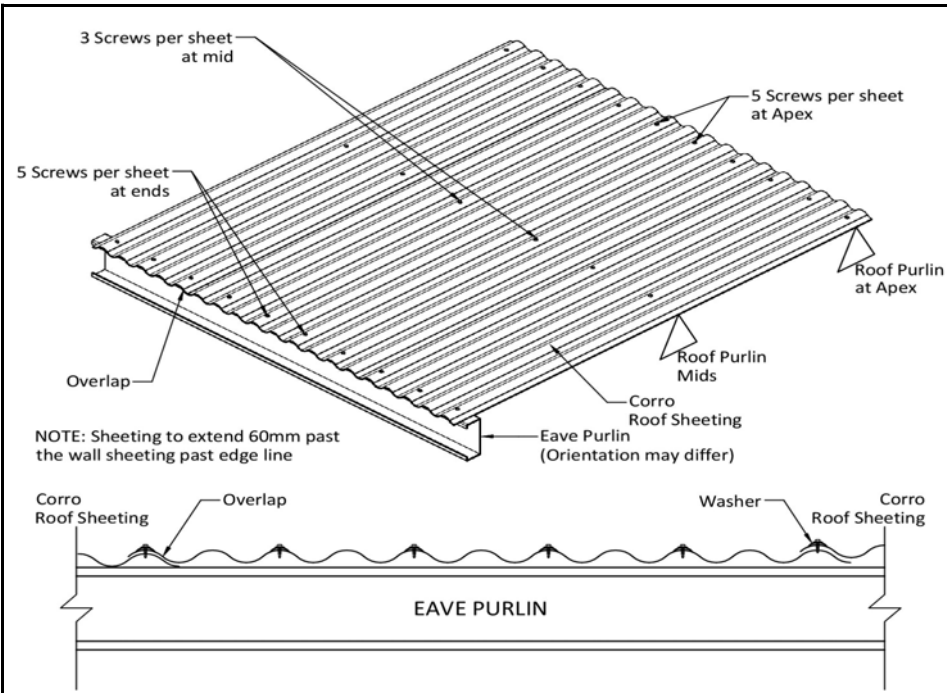

Roofing Screws - 12.14 x 42 Hex Seal High Grip
CORRO ROOF SHEET FIXING

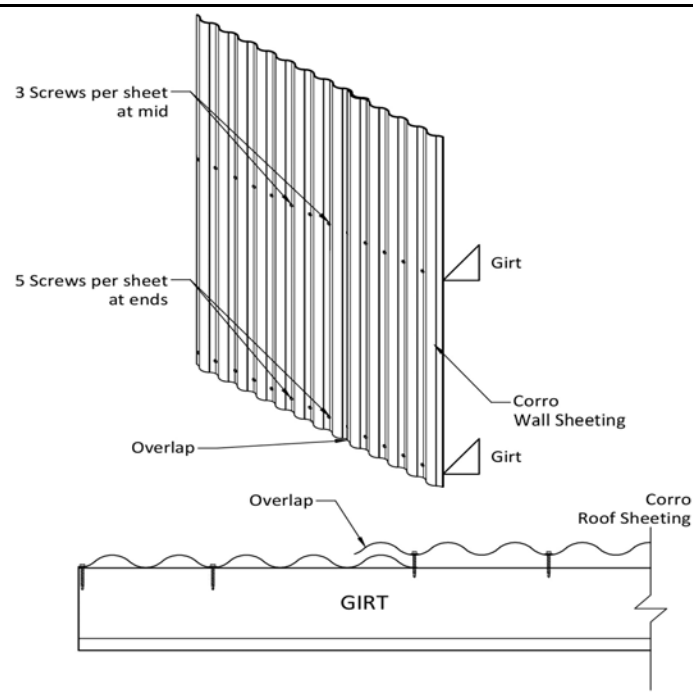

Wall Screws - 10.16 x 16 Hex
WALL SHEETING CONNECTION DETAILS

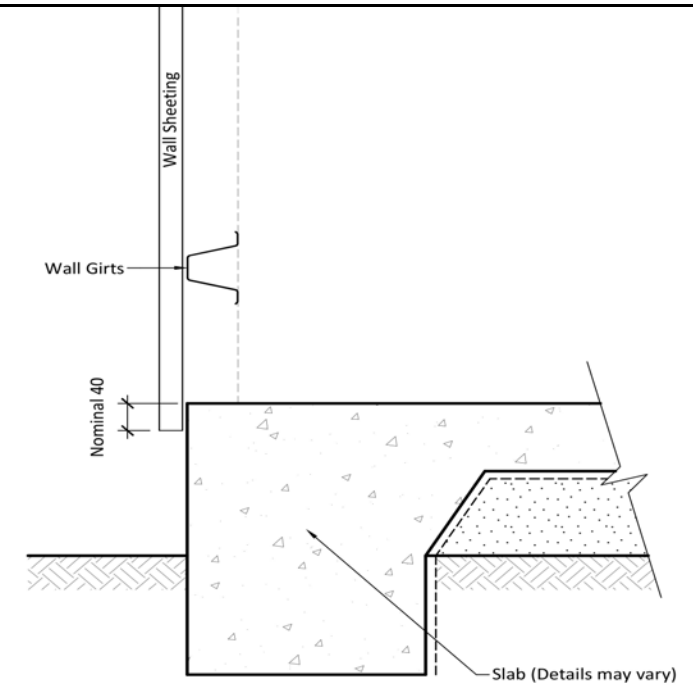

WALL SHEET OVERHANG DETAIL

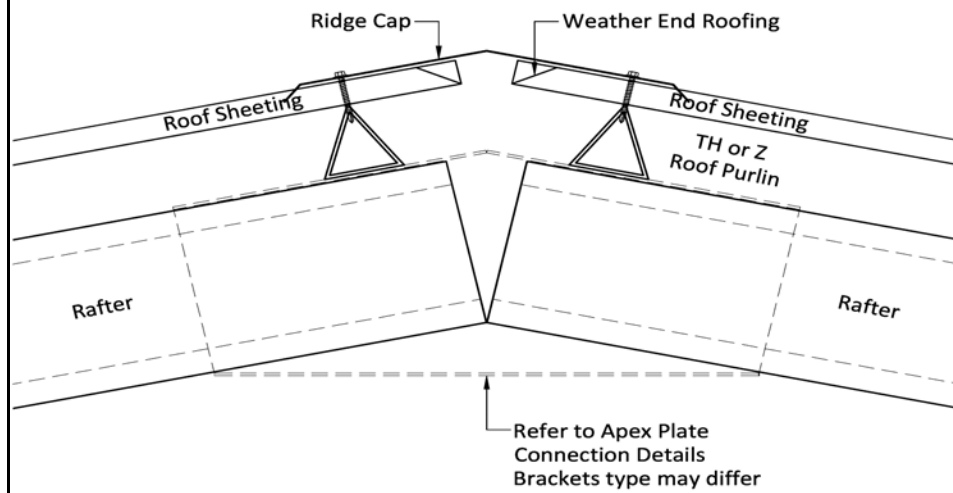

Ridge Cap - 2XF280

Purchaser Name: Jason Brown	
Site Address: 13 Robert Jones St Mudgee NSW 2850 Australia	
Drawing # TMJD240033 - 8	Print Date: 13/08/24

Connection Details
 Not to Scale
 Page 5 of 6
 © Copyright Steelx IP Pty Ltd

Seller: THE Shed Company Mudgee
 S & K Lincoln Pty Ltd
 Phone: (02) 6372 7755
 Fax: (02) 6372 7700
 Email: mudgeeadmin@theshedcompany.com.au

Apex Engineering Group PTY LTD
 ACN 632 588 562
 ME Aust. (Registered NER Structural) 5276680
 QLD : RPEQ No. 24223; TAS : 185770492; VIC : PE0003848; N.T : 303557ES;
 Practising Professional Structural & Civil Engineers

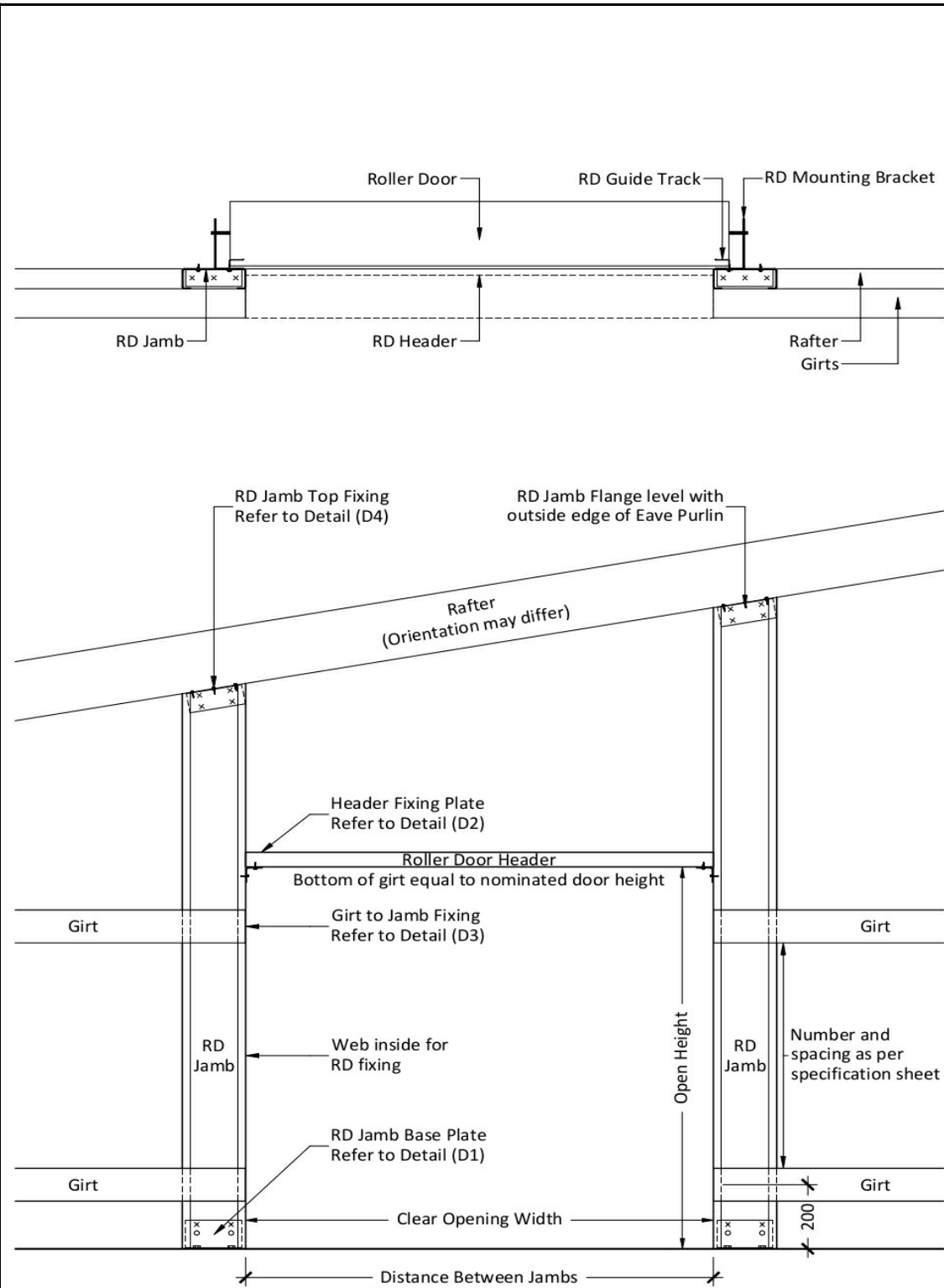

Door Width	Max Opening
≤3.1m	Door Width -50mm
>3.1m or ≤5.1m	Door Width -100mm

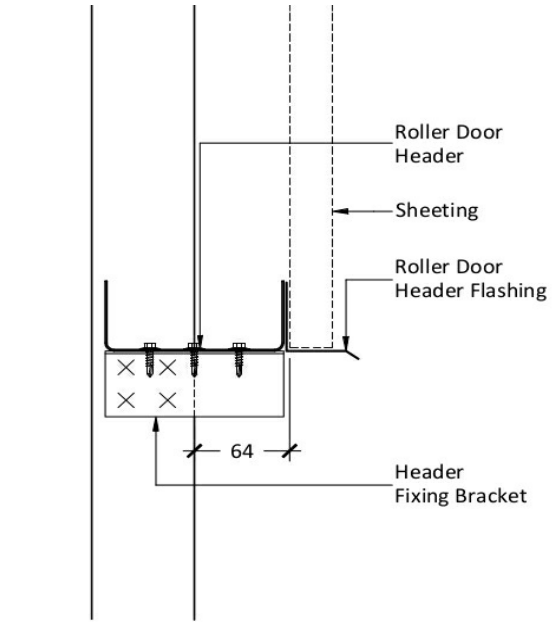

× FIXING SCREWS - 7 of 14.20 x 22
DETAIL (D4) - RD JAMB TOP FIXING

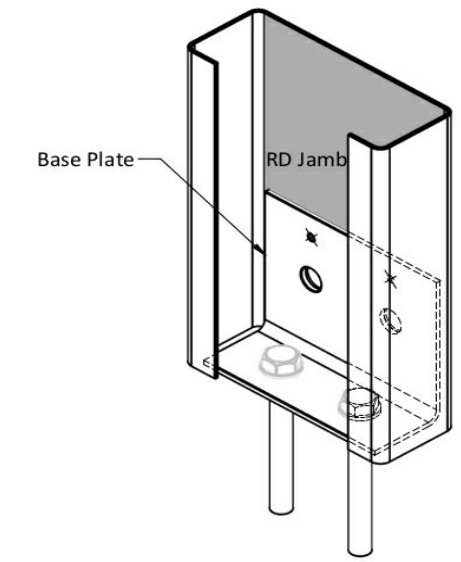
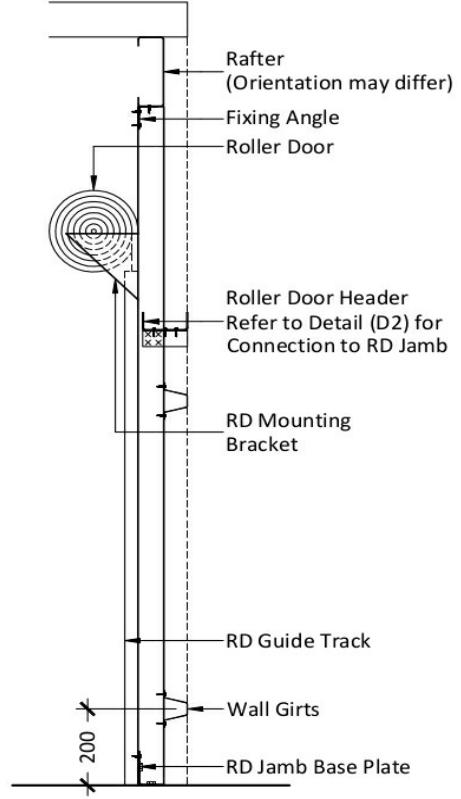

2 of M12 x 75 DYNABOLTS - FOR C150 & C200 JAMBS
 2 of M16 x 110 DYNABOLTS - FOR C250 & C300 JAMBS
 ○ FIXING BOLTS - 2 of M12 x 30 - FOR C150 & C200 JAMBS
 ○ FIXING BOLTS - 2 of M16 x 30 - FOR C250 & C300 JAMBS
 × FIXING SCREWS - 2 of 14.20 x 22
DETAIL (D1) - RD JAMB BASE PLATE

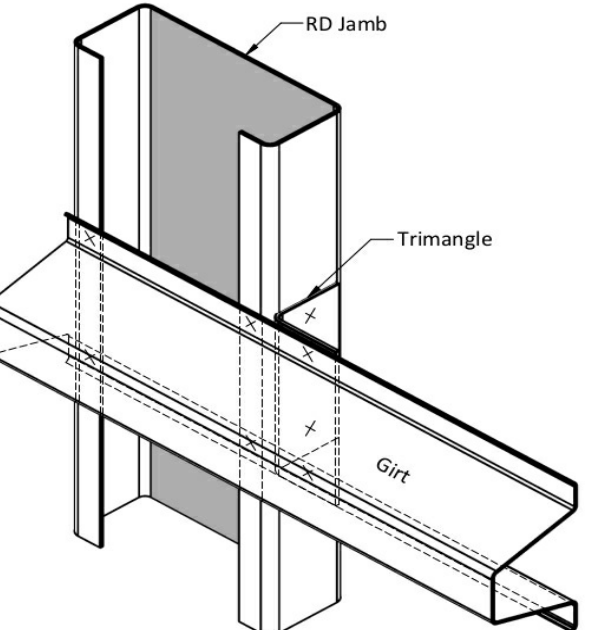
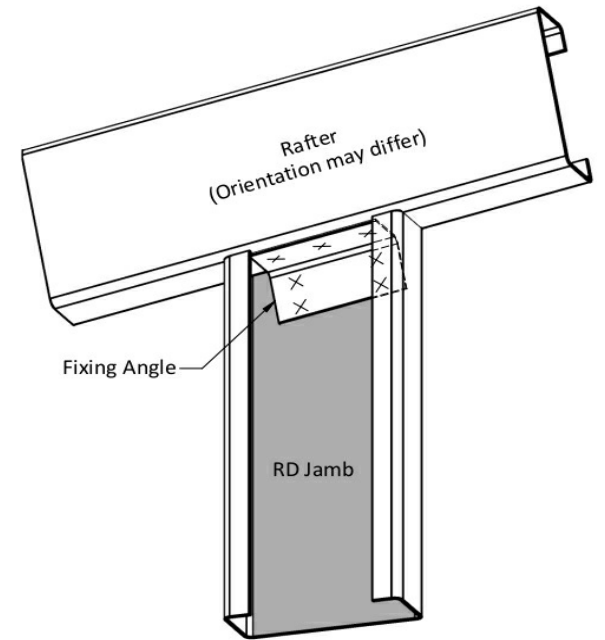

FIXING SCREWS - 4 of 14.20 x 22 TO JAMB LIPS
 × 4 of 14.20 x 22 TO TRIMANGLE
DETAIL (D3) - GIRT FIXING TO RD JAMB

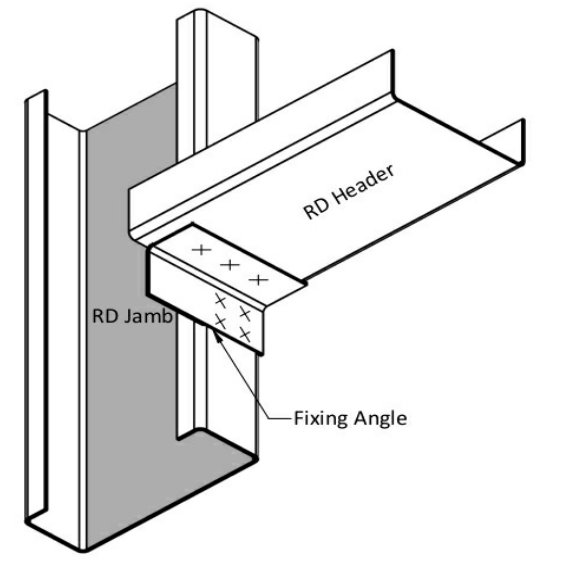

× FIXING SCREWS - 7 of 14.20 x 22
DETAIL (D2) - RD HEADER FIXING

Purchaser Name: Jason Brown

Site Address: 13 Robert Jones St Mudgee NSW2850 Australia

Drawing # TMJD240033 - 8

Print Date: 13/08/24

Connection Details

Not to Scale
 Page 6 of 6
 © Copyright Steelx IP Pty Ltd

Seller: THE Shed Company Mudgee
 S & K Lincoln Pty Ltd
 Phone: (02) 6372 7755
 Fax: (02) 6372 7700
 Email: mudgeeadmin@theshedcompany.com.au

Apex Engineering Group PTY LTD
 ACN 632 588 562
 ME Aust. (Registered NER Structural) 5276680
 QLD : RPEQ No. 24223; TAS : 185770492; VIC : PE0003848; N.T. : 303557ES;
 Practising Professional Structural & Civil Engineers

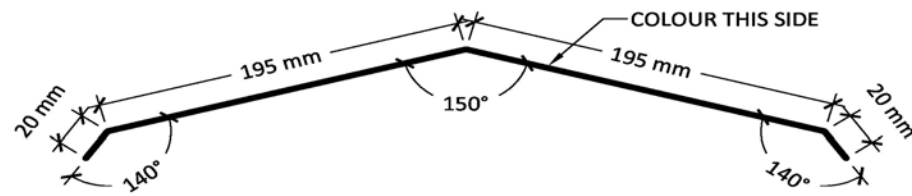

15° Ridge Capping - Top Hat - Corodek
2XF280

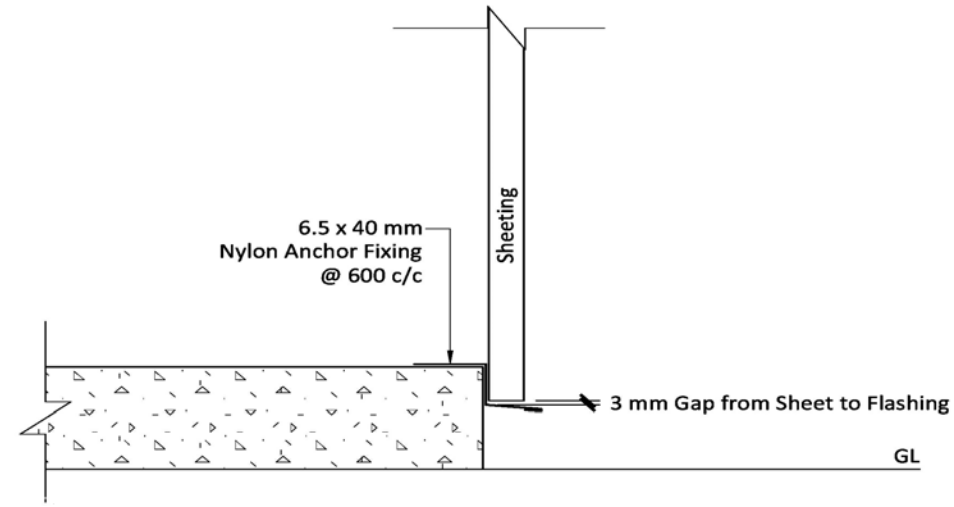

Vermin Flashing FLASH-VERM-01

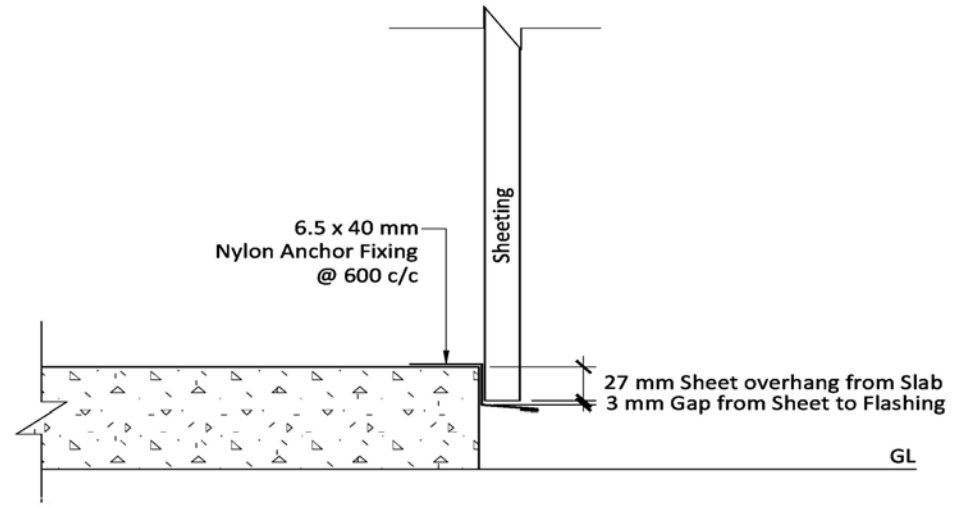

Vermin Flashing - FLASH-VERM-01

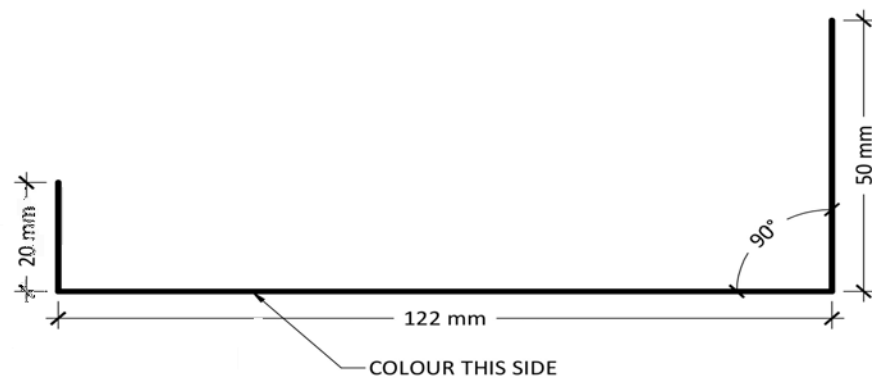

RD Head Cover Flashing
XF116

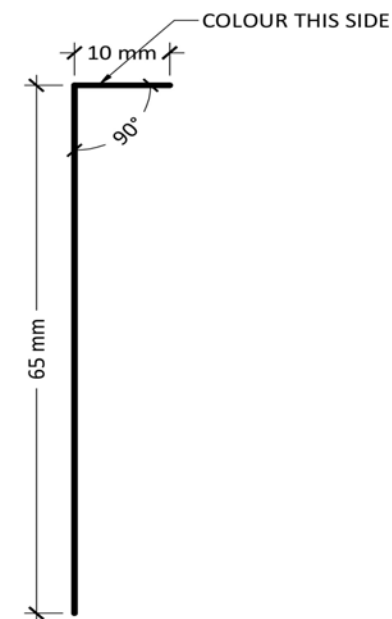

RD Side - Cover Flash
XF18

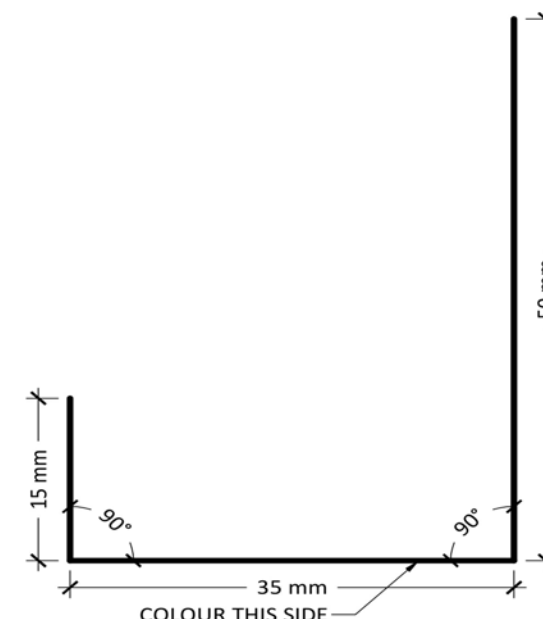

PA Door - RD Header Flashing
XF24

Purchaser Name: Jason Brown

Site Address: 13 Robert Jones St Mudgee NSW 2850 Australia

Drawing # TMJD240033 - 9

Print Date: 13/08/24

Flashing Fixing Details
Not to Scale
Page 1 of 2
© Copyright Steelx IP Pty Ltd

Seller: THE Shed Company Mudgee
S & K Lincoln Pty Ltd
Phone: (02) 6372 7755
Fax: (02) 6372 7700
Email: mudgeeadmin@theshedcompany.com.au

Apex Engineering Group PTY LTD
ACN 632 588 562
ME Aust. (Registered NER Structural) 5276680
QLD : RPEQ No. 24223; TAS : 185770492; VIC : PE0003848; N.T. : 303557ES;
Practising Professional Structural & Civil Engineers

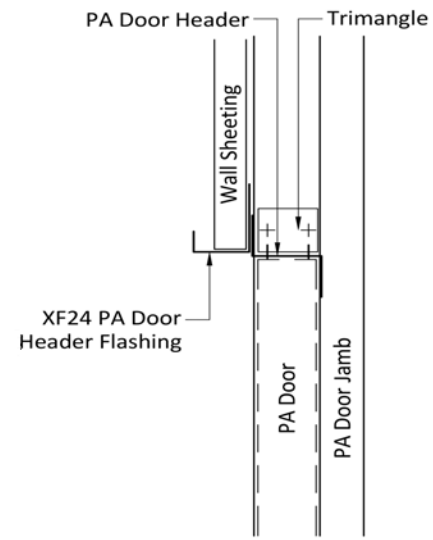

PA Door Header Flashing - XF24

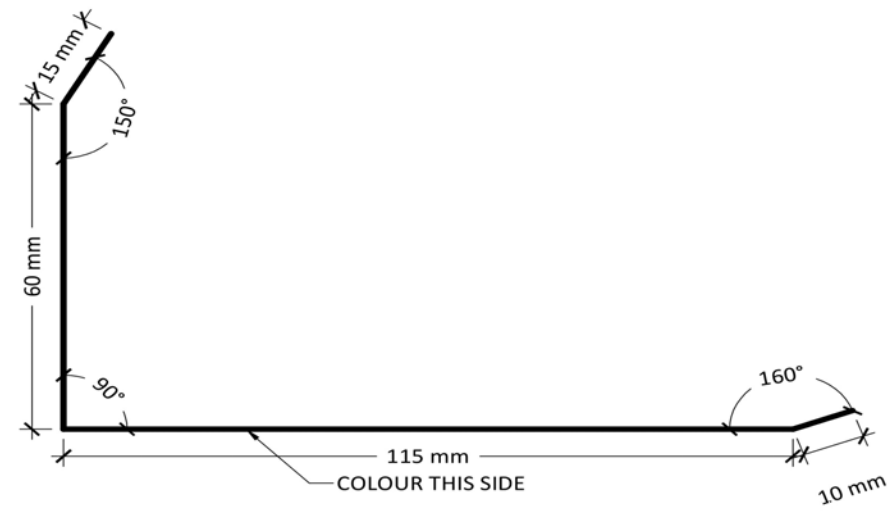

Roller Door Side Flashing - End Walls
XF27

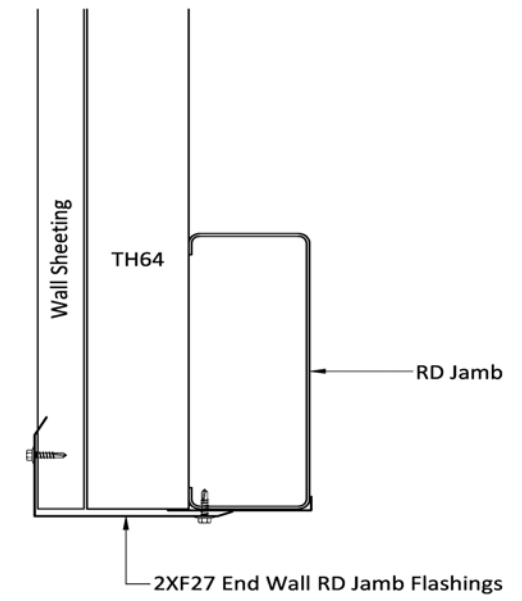

End Wall RD Jamb Flashing 2XF27/18

Purchaser Name: Jason Brown

Site Address: 13 Robert Jones St Mudgee NSW 2850 Australia

Drawing # TMJD240033 - 9

Print Date: 13/08/24

Flashing Fixing Details

Not to Scale
Page 2 of 2
© Copyright Steelx IP Pty Ltd

Seller: THE Shed Company Mudgee
S & K Lincoln Pty Ltd
Phone: (02) 6372 7755
Fax: (02) 6372 7700
Email: mudgeeadmin@theshedcompany.com.au

Apex Engineering Group PTY LTD
ACN 632 588 562
ME Aust. (Registered NER Structural) 5276680
QLD : RPEQ No. 24223; TAS : 185770492; VIC : PE0003848; N.T. : 303557ES;
Practising Professional Structural & Civil Engineers

This setout is provided as a guide only. It is the responsibility of the concreter/erector to confirm that all dimensions are correct.

Right Side

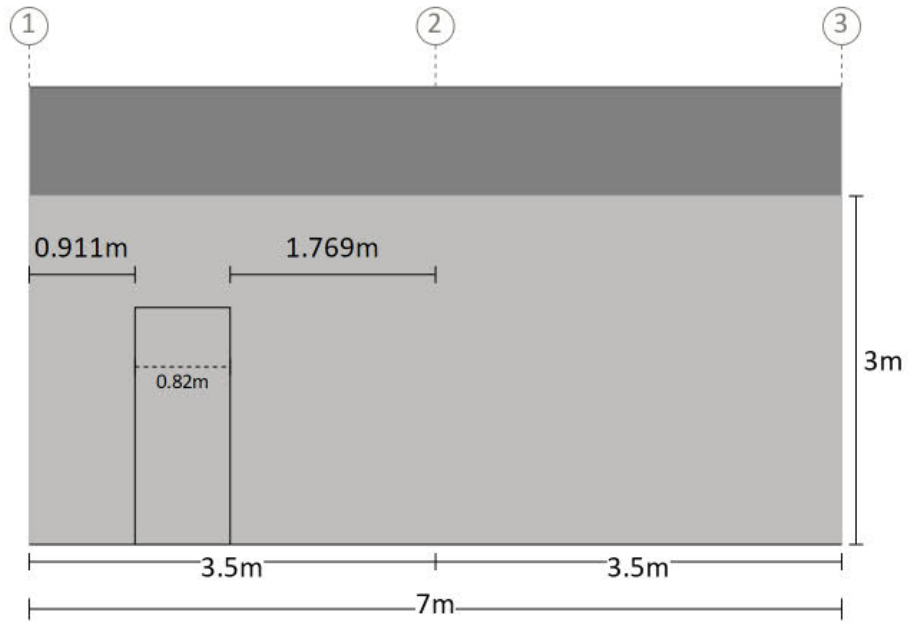

Measurements are from the outside of end girts (end bays) and/or centre of columns (mid bays) to inside of component opening size.

Left End

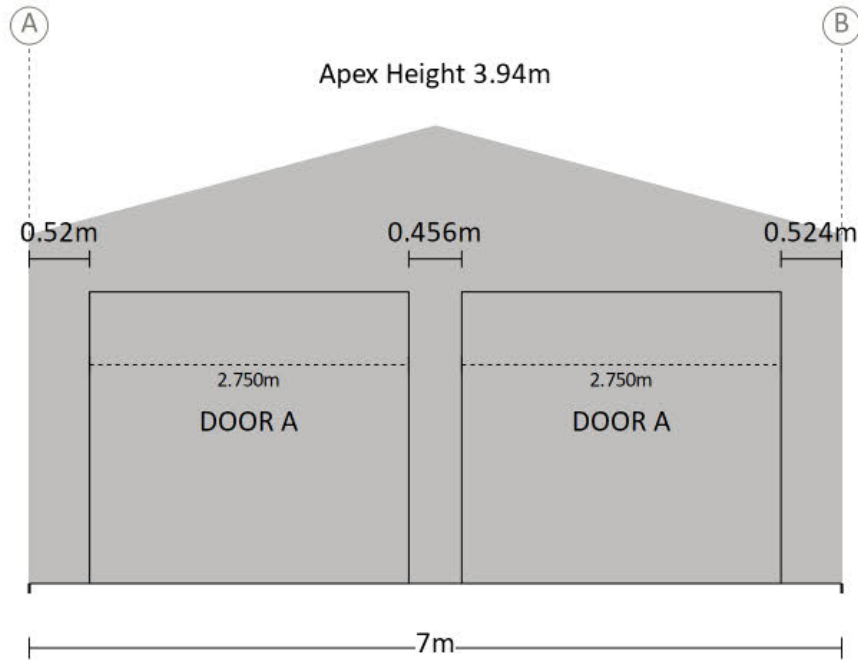

Purchaser Name: Jason Brown

Site Address: 13 Robert Jones St Mudgee NSW 2850 Australia

Drawing # TMJD240033 - 10

Print Date: 13/08/24

Component Position

Not to Scale
Page 1 of 1
© Copyright Steelx IP Pty Ltd

Seller: THE Shed Company Mudgee
S & K Lincoln Pty Ltd
Phone: (02) 6372 7755
Fax: (02) 6372 7700
Email: mudgeeadmin@theshedcompany.com.au

Apex Engineering Group PTY LTD
ACN 632 588 562
ME Aust. (Registered NER Structural) 5276680
QLD : RPEQ No. 24223; TAS : 185770492; VIC : PE0003848; N.T : 303557ES;
Practising Professional Structural & Civil Engineers